

Integral geometry and curvature integrals in hyperbolic
space.

Gil Solanes

April 29, 2003

Contents

1	Mean curvature integrals	13
1.1	Hyperbolic space	13
1.1.1	Definition and basic facts	13
1.1.2	Moving frames	15
1.1.3	Models	19
1.2	Mean curvature integrals	21
2	Spaces of planes	27
2.1	Spaces of planes	27
2.1.1	Invariant metrics and measures	29
2.2	Kinematic formulas	33
2.3	The de Sitter sphere	37
2.3.1	Spaces of planes in the de Sitter sphere	40
2.3.2	The Gauss map	42
2.4	Contact measures.	46
2.5	Cauchy-Crofton formula in the de Sitter sphere.	48
3	Total Curvature	53
3.1	The Gauss-Bonnet Theorem in Euclidean Space	53
3.2	The Gauss-Bonnet Theorem in the sphere	55
3.3	Variation Formulas.	60
3.4	The Gauss-Bonnet Theorem in Hyperbolic space	66
3.5	Total Absolute Curvature in Hyperbolic Space	70
3.5.1	Total Absolute Curvature in Euclidean Space	70
3.5.2	Surfaces in Hyperbolic 3-Space.	72
3.5.3	Tight Immersions in Hyperbolic Space	75
4	Inequalities between mean curvature integrals	85
4.1	Introduction	85
4.2	Inequalities between Quermassintegrale	87
4.3	Slice expectation for random geodesic planes	91
4.4	Inequalities between the mean curvature integrals	92
4.5	Examples	96

5	Integral geometry of horospheres and equidistants	101
5.1	Introduction	101
5.2	Definitions and invariant measures	102
5.3	Volume of intersections with λ -geodesic planes	104
5.4	Mean curvature integrals of intersections with λ -geodesic planes	106
5.5	Measure of λ -geodesic planes meeting a λ -convex domain.	111
5.6	h -convex domains	112
5.7	Expected slice with λ -geodesic planes	115

Introduction

The sum of the inner of a hyperbolic triangle is always below π . The difference with that value is the so-called *defect* of the triangle, and coincides with its area. This result belongs to the beginnings of non-euclidean geometry but it is also a consequence of the well-known Gauss-Bonnet theorem. By virtue of this theorem, the integral of the geodesic curvature along a smooth simple closed curve in hyperbolic plane is known to be the area of the bounded domain plus the Euler characteristic of this domain multiplied by 2π . The *defect* of a curve in hyperbolic plane could be defined to be the difference between its geodesic curvature integral and that of a topologically equivalent curve in euclidean plane. Then one would state that the defect of a hyperbolic plane curve is the area of the domain it bounds. Such a defect would measure the extra effort that a sailor needs to make at the rudder in order to make the ship give a complete loop when sailing in a hyperbolic sea.

When going to dimension 3, the Gauss-Bonnet theorem states that the Gauss curvature integral of a closed surface is 2π times its Euler characteristic plus its area. Then one can say that the defect of such a surface equals its area. In particular it is clear that surfaces in hyperbolic space must provide more curvature than in euclidean space in order to get closed.

In hyperbolic space of general dimension one finds a quite disappointing version of the Gauss-Bonnet theorem: for even n and a domain $Q \subset \mathbb{H}^n$ of volume V ,

$$M_{n-1}(\partial Q) + c_{n-3}M_{n-3}(\partial Q) + \cdots + c_1M_1(\partial Q) + (-1)^{n/2}V = O_{n-1}\chi(Q)$$

while for odd n ,

$$M_{n-1}(\partial Q) + c_{n-3}M_{n-3}(\partial Q) + \cdots + c_2M_2(\partial Q) - M_0(\partial Q) = \frac{O_{n-1}}{2}\chi(\partial Q)$$

where O_i is the volume of the i -dimensional unit sphere, the constants c_i depend only on the dimension, and $M_i(\partial Q)$ is the integral over ∂Q of the i -th mean curvature function. In particular $M_{n-1}(\partial Q)$ is the Gauss curvature integral or *total curvature* of ∂Q . This Gauss-Bonnet formula is deduced from the general intrinsic version proved by Chern for abstract riemannian manifolds. However it is too bad to loose the simplicity we had in dimensions 2 and 3. For instance, its is not so clear, even for a convex Q , whether if the total curvature is greater in hyperbolic or in euclidean space. Nevertheless, integral geometry will allow us to give a much smarter version of the Gauss-Bonnet theorem in

hyperbolic space. Indeed, it will be proved

$$M_{n-1}(\partial Q) = O_{n-1}\chi(Q) + c \int_{\mathcal{L}_{n-2}} \chi(L_{n-2} \cap Q) dL_{n-2} \quad (1)$$

where \mathcal{L}_{n-2} is the space of codimension 2 totally geodesic planes of \mathbb{H}^n , and dL_{n-2} is the invariant measure in this space. This way, the defect of a hyperbolic closed hypersurface is the measure with some multiplicity of the set of codimension 2 planes intersecting it. Integral geometry allows not only to state such a pretty formula but it is also the key tool for the proof. Since one can easily deduce the Gauss-Bonnet theorem in \mathbb{H}^n from this formula, we will get a new proof of this theorem using the methods of integral geometry.

This remarkable fact has an equivalent in spherical geometry that was already discovered by E. Teufel in [Teu80]. In this case, the integral over the space on $(n-2)$ -planes in formula (1) appears with a minus sign. Let us take a look to the proof in this spherical case, and we will have an idea of the difficulties hidden in the hyperbolic case. To simplify take a strictly convex domain $Q \subset \mathbb{S}^n$. Then one can define a Gauss map γ by taking the inner unit normal vector at the points of $S = \partial Q$. The image $\gamma(S)$ of such a Gauss map is a hypersurface in \mathbb{S}^n with volume equal to the total curvature of S . This is due to the fact that the Gauss curvature at a point is the infinitesimal volume deformation of γ . On the other hand, the Cauchy-Crofton formula in \mathbb{S}^n allows to compute this volume by just integrating the number of points where $\gamma(S)$ is cut by all the great circles of \mathbb{S}^n . Up to some constant, one has that $M_{n-1}(S)$ is the integral of the number of intersection points $\#(l \cap \gamma(S))$ over the space of great circles l of \mathbb{S}^n . Consider the bundle of hyperplanes orthogonal to a great circle l . They all contain a common $(n-2)$ -plane L_{n-2} which we call the *pole* of l . Moreover, every point of $l \cap \gamma(S)$ corresponds to a hyperplane of the bundle that is tangent to S . But, depending on whether the pole L_{n-2} meets S or not, the hyperplane bundle has none or two hyperplanes tangent to S . Therefore, the total curvature of S is, up to some constant, the difference of the total measure of $(n-2)$ -planes with the measure of those planes meeting the convex Q .

The general plan for hyperbolic space is similar. Consider a strictly convex domain $Q \subset \mathbb{H}^n$ in the hyperboloid model

$$\mathbb{H}^n = \{x \in \mathbb{R}^{n+1} \mid L(x, x) = -1 \ x_0 > 0\}$$

with the Lorentz metric $L(x, y) = -x_0y_0 + x_1y_1 + \dots + x_ny_n$. Take, at every point in $S = \partial Q$, the inner unit normal vector. This is a space-like vector of \mathbb{R}^{n+1} ; so one has a Gauss map γ from S to the following quadric, called *de Sitter sphere*,

$$\Lambda^n = \{x \in \mathbb{R}^{n+1} \mid L(x, x) = 1\}.$$

The image $\gamma(S)$ is a space-like hypersurface and, as in \mathbb{S}^n , the Gauss curvature integral over S coincides with the volume of this image. The next step would be to use a Cauchy-Crofton formula in Λ^n to find the volume of $\gamma(S)$. Unfortunately, such a formula does not exist. In fact, the set of lines in Λ^n intersecting any small piece of hypersurface has

infinite measure. This was the *hidden difficulty* of hyperbolic space: one needs to do integral geometry in a Lorentz space, and this gives some difficulties. That the target of the Gauss map of \mathbb{H}^n is a Lorentz manifold is not accidental, nor it is due to the fact that we have used a model contained in Minkowski space. As we will see, the reasons for this fact are closely related to the existence of ultraparallel hyperplanes. Therefore, it is a fact *deeply* related to the geometrical properties of hyperbolic space, and not to those of any particular model.

However, we will here get over this difficulty while getting a Cauchy-Crofton-like formula for hypersurfaces of Λ^n . To be precise we will prove

$$\int_{\mathcal{L}} (2 - \#(l \cap R)) dl = \frac{O_{n-2}}{n-1} (\text{vol}(R) - O_{n-1})$$

where R is any space-like hypersurface embedded in Λ^n , and \mathcal{L} stands for the set of space-like geodesics l . Then one can apply this formula to the hypersurface $R = \gamma(S)$. For every vector of some space-like geodesic in Λ^n , take the orthogonal subspace with respect to the Lorentz metric. We get a bundle of hyperplanes in \mathbb{H}^n containing all of them an $(n-2)$ -dimensional geodesic plane L_{n-2} of \mathbb{H}^n . Now, the intersections of l and $\gamma(S)$ correspond to hyperplanes of the bundle tangent to S . Depending whether L_{n-2} meets S or not, the hyperplanes bundle has none or two of these tangent hyperplanes. Then we have seen that the measure of $(n-2)$ -planes meeting Q is, up to some constant, the total curvature of its boundary minus O_{n-1} .

Even if the previous lines contain the idea of the proof, it must be noticed that in the general case one has to proceed more carefully, since the Gauss image of a non-strictly convex surface can be far away from being embedded.

It is not surprising that integral geometry allows to prove the Gauss-Bonnet theorem. Indeed, curvature integrals appear in many of the formulas of integral geometry. It is also usual that through this relationship integral geometry allows to draw conclusions on total curvature. For instance, the Fenchel-Fary-Milnor theorem for closed curves is proved by just applying the Crofton formula to the spherical image of the unit tangent vector of the curve. A similar result is the Chern-Lashof inequality. Recall that it states, for any compact submanifold S immersed in \mathbb{R}^n , that its total absolute curvature $\text{TAC}(S)$ is bounded by

$$\text{TAC}(S) \geq \frac{O_{n-1}}{2} \beta(S)$$

where $\beta(S)$ is the sum of the Betti numbers of S . In the equality case S is called *tight*. Tight immersions have been widely studied, and have been geometrically characterized in many different ways. Recalling what we said in the beginning about how hypersurfaces in hyperbolic space need much more curvature in order to get closed, one is lead to think that the last inequality, being true in \mathbb{R}^n , should also be true in \mathbb{H}^n . However, it was seen in [LS00] that this is false. To be precise, there one constructs orientable surfaces S in \mathbb{H}^3 with a big genus g , such that its total absolute curvature is below $2\pi\beta(S) = 2\pi(2 + 2g)$. Here we will do the same but for any genus $g > 1$. Having no Chern-Lashof inequality, it is not clear what should tightness mean for submanifolds of

\mathbb{H}^n . However, following the geometrical characterizations of tight immersions in \mathbb{R}^n , we will give a natural definition of tightness in \mathbb{H}^n . The natural question is then: what is the difference between the total absolute curvature of an immersion in \mathbb{H}^n and that of its euclidean equivalent? We are asking for the defect in total absolute curvature of a tight immersion in hyperbolic space. The answer will be again given in the ‘language’ of integral geometry. To be precise, we will prove that this ‘absolute defect’ is

$$\int_S |K| dx - \frac{O_{n-1}}{2} \beta(S) = \frac{O_{n-2}}{n-1} \int_{\mathcal{L}_{n-2}} (\beta(S) - \nu(S, L)) dL$$

being $\nu(S, L)$ the number of hyperplanes containing L_{n-2} and tangent to S . This defect is not always positive; in the examples of [LS00] it must be negative. However, we will show that the absolute defect of a tightly immersed torus is positive. So for tight tori in \mathbb{H}^n the Chern-Lashof inequality does hold.

Hypersurfaces in hyperbolic space are not only more curved than in euclidean but they also have a greater volume. Let us recall, for instance, that for a domain $Q \subset \mathbb{H}^n$ the boundary has more volume than the interior. More precisely

$$\text{vol}(\partial Q) > (n-1)\text{vol}(Q).$$

This shocks to our intuition since in euclidean geometry these two volumes have different orders. For instance, after a homothety of factor ρ the volume of Q is multiplied by ρ^n and that of ∂Q is multiplied by ρ^{n-1} . This implies that $\text{vol}(Q)$ and $\text{vol}(\partial Q)$ can not be ‘compared’ in euclidean space. Nevertheless, they can be in hyperbolic space. This is due to the fact that the negative curvature of the space gives much more ‘content’ to the boundary. Adding this to the idea that this boundary is also more curved, one can think of inequalities in the style of $\text{vol}(Q) < cM_{n-1}(Q)$ or $\text{vol}(\partial Q) < cM_{n-1}(Q)$. We will prove such inequalities for Q convex. To be precise we will show that there are constants such that for any convex $Q \subset \mathbb{H}^n$

$$M_i(\partial Q) < c \text{vol}(Q) \quad M_i(\partial Q) < c_{ij} M_j(\partial Q) \quad \text{for } i < j$$

where M_i stands again for the i -th mean curvature integral. These inequalities are once again completely impossible in euclidean geometry, since the mean curvature integral M_i has order $n-i-1$. In other words, after stretching Q through a homothety of factor ρ , the i -th mean curvature integral of its boundary becomes $M_i(\partial(\rho Q)) = \rho^{n-i-1} M_i(\partial Q)$.

In order to prove these inequalities, equation (1) will play an important role. Using the reproductive properties of M_i , this formula gives

$$M_i(\partial Q) = cW_{i-1}(Q) + c'W_{i+1}(Q)$$

where $W_i(Q)$ is the usually called *Quermassintegrale* of Q and stands, up to constants, for the measure of i -planes meeting the convex Q . Thus, we will start looking for inequalities between the W_i . From them one will deduce, by the previous formula, inequalities between the M_i . The former inequalities will be in the style of $W_i(Q) < cW_{i+1}(Q)$. In

particular one will have $\text{vol}(Q) < cW_i(Q)$. This inequality has an amazing interpretation in terms of geometric probabilities. Indeed, throwing an i -plane L randomly to meet a convex body Q , and measuring the volume of the intersection $L \cap Q$ one gets a random variable λ_i . The mathematical expectation of such a random variable is $E[\lambda_i] = c \cdot \text{vol}(Q)/W_i(Q)$. Thus, the previous inequality amounts to give an upper bound for the mathematical expectation of a random i -dimensional plane slice of a convex body. And this bound is a constant not depending on how big is the body!

Besides of this interpretation, the inequalities between the Quermassintegrale $W_i(Q)$ will allow to prove for any convex $Q \subset \mathbb{H}^n$

$$M_i(\partial Q) < M_j(\partial Q) \quad \text{for } j > i + 1$$

and these inequalities are sharp. Indeed, it is easy to see that for a ball B with radius growing to infinity $M_i(\partial B)/M_j(\partial B)$ approaches to 1. We will also find constants such that

$$M_i(\partial Q) < c_i M_{i+1}(\partial Q)$$

but in this case the constants will not be shown to be optimal.

Going back to the expectation of random plane slices, it is also interesting to look at the intersections with different submanifolds randomly thrown. In particular, it is natural to look at the problem with horospheres and equidistants playing the role of geodesic planes. Equidistants and horospheres are two kinds of hypersurface very specific of hyperbolic geometry, where, in some sense, are analogues of euclidean affine hyperplanes. Indeed, in euclidean geometry one can think of affine hyperplanes as spheres of infinite radius. One can also say that hyperplanes and spheres are the only hypersurfaces with constant normal curvature. On the other hand, in hyperbolic geometry, a sphere with center going to infinity approaches a hypersurface called a horosphere. Besides, spheres in \mathbb{H}^n have normal curvature greater than 1. So it is clear that between geodesic hyperplanes and metric spheres there should be a range of hypersurfaces with constant normal curvature between 0 and 1. These are the so-called equidistants and horospheres. The former have constant normal curvature below 1 and its points are all at the same distance from some geodesic hyperplane. About horospheres, they have normal curvature 1 and we already said that they are limits of spheres. Thus, horospheres and equidistants have a strong analogy with affine hyperplanes of euclidean geometry. Therefore, integral geometry in hyperbolic space should deal with these hypersurfaces in the same way as it deals with affine planes in euclidean space. For horospheres, this study was started by Santaló in [San67] and [San68] in dimensions 2 and 3, and was followed by Gallego, Martínez Naveira and Solanes in [GNS] for higher dimensions. The case of equidistant hypersurfaces is treated here for the first time, together with the previous one.

An outstanding fact is that the measure of horoballs (convex regions bounded by horospheres) containing a compact set is finite. After, this fact will allow to prove some geometric inequalities for h -convex sets (or convex with respect to horospheres). Finally we will see that, the same as for geodesic planes, the expected volume of the intersection of a domain with a random horosphere or equidistant is bounded above, no matter how big the domain is.

Next we explain the organization of the text. Chapter 1 contains some preliminaries about hyperbolic space \mathbb{H}^n and mean curvature integrals of hypersurfaces. There are also some computations with moving frames which will be the basic tool for the rest of the chapters. Moreover, the moving frames method will allow us to work without any particular model of hyperbolic space. Only in some moments we will use the projective model, and just in a synthetic way. It is worthy to say that everything we will do could also be done working with the hyperboloid model. However, we have preferred to avoid the models in order to show clearly the geometrical reasons leading to semi-riemannian metrics.

Chapter 2 studies the spaces consisting of geodesic planes in \mathbb{H}^n . We pay special attention to its semi-riemannian structure invariant under the action of the isometry group of \mathbb{H}^n . As a particular case, we identify the de Sitter sphere Λ^n to the space of oriented hyperplanes of \mathbb{H}^n . In this space we also introduce moving frames and we study the duality relationship between Λ^n and \mathbb{H}^n . We also generalize to Λ^n some results on contact measures which are known in constant curvature riemannian manifolds. These results are used to finish the chapter with a Cauchy-Crofton formula in Λ^n . This formula is one of the main results of this work and its proof will inspire great part of the content of the next chapter.

Chapter 3 treats on total curvature of hypersurfaces. In a first part, one studies the Gauss curvature integral of closed hypersurfaces. This is done from the point of view of integral geometry, which presents some advantages with respect to the intrinsic viewpoint. After recalling briefly the euclidean and spherical cases, one proceeds to hyperbolic space. The result is the formula (1) which leads to a new proof of some integral geometric formulas as well as of the Gauss-Bonnet theorem in hyperbolic space.

The second part of the chapter is concerned on the study of total absolute curvature (in the sense of Chern and Lashof). After recalling briefly the classical theory in euclidean space, we start the study of surfaces in \mathbb{H}^3 . The most important point in this section are some examples showing that the Chern-Lashof inequality does not hold in hyperbolic geometry. Next we give a definition of tightness for submanifolds in \mathbb{H}^n , which is analogous in many aspects to the euclidean definition. Finally, we get a kinematic formula which allows to measure the difference between the total absolute curvature of a tight submanifold in \mathbb{H}^n and that of its euclidean analogue. From this formula one can deduce that tight tori in \mathbb{H}^n do fulfill the Chern-Lashof inequality.

In chapter 4 one gets inequalities relating the mean curvature integrals of the boundary of a convex body. The first step is to compare the measure of the set of planes meeting the convex body for different dimensions of the planes. This is done by means of a rather elementary but quite original and effective geometric argument. This result is interpreted in terms of the expectation of the volume of the intersection of a random plane meeting a fixed domain. Then, we get some inequalities for the mean curvature integrals, and finally some examples are constructed showing that many of the obtained inequalities are sharp.

The last chapter generalizes the classical formulas of integral geometry to horo-

spheres and equidistant hypersurfaces. Both cases are treated together with those of geodesic planes and spheres, since one deals with totally umbilical hypersurfaces of any normal curvature. Next we use the results about horospheres to prove certain geometric inequalities for h -convex domains. Finally we get results about the expectation of the volume of the intersection between a randomly moving totally umbilical hypersurface and a fixed domain.

Acknowledgments

This thesis would not have been possible without the help of many people. The first of them is Eduard Gallego who has been its director giving me always help and advice, as well as a permanent support. He has always been ready to hear me, and to encourage me when necessary. But even more than all this, I am grateful to him to introduce me in such a pretty field as integral geometry.

I am also in debt to Agustí Reventós for his interest and good disposition. We have spent many whiles in his office discussing about geometry. Concerning Rémi Langevin, I must thank him for his hospitality in my stays at Dijon. Also, his intuition for finding counterexamples saved me from a way leading nowhere. I also consider myself lucky to have had the possibility to collaborate with professor Antonio M. Naveira. He is who started the work in the last chapter, and generously encouraged us to join. In the background of this thesis there are also the works of professor Eberhard Teufel. Without his done work, I could not go very far. He has also been very kind, and gave me advise many times.

On the other hand it is clear that this work has needed the research spirit that is always present at the Departament de Matemàtiques of the UAB. In particular between the members of the geometry group, who have given me support in so many things. I want to mention specially Joan Porti, my office partner, who has also helped me often.

Without my lunch partners this thesis may not have been possible. Their good humour gave me courage in the difficult moments.

Finally I am in debt to my family for supporting me at any moment. This thesis is dedicated to Maira, who has always been by my side.

Chapter 1

Mean curvature integrals

1.1 Hyperbolic space

In this section we introduce hyperbolic space and we outline some of the fundamental facts of its geometry.

1.1.1 Definition and basic facts

There are several models of hyperbolic space. Between the most known are the Poincaré half-space and ball, the hyperboloid and the projective (or Klein, or Beltrami) model. The hyperboloid is the most used in integral geometry (cf. [San76]). However, here we will use exclusively the projective model and only eventually. Indeed, in order to give the most geometric view, we will take an abstract viewpoint; i.e. not using any model when possible. Thus, to do computations we will use some classical techniques from riemannian geometry as geodesic coordinates, Jacobi fields, moving frames, etc. Besides, the formulas of hyperbolic trigonometry will be very useful.

Definition 1.1.1. *Hyperbolic space* of dimension n , denoted \mathbb{H}^n , is the (only up to isometry) n -dimensional complete, simply connected riemannian manifold with constant sectional curvature -1 .

As known, the unicity comes from Cartan's classification theorem ([Car51, p.238]). This theorem implies the following property, general for spaces of constant curvature.

Proposition 1.1.1. *The isometry group of \mathbb{H}^n acts transitively on the orthonormal frames. That is, given two points $p, q \in \mathbb{H}^n$ and orthonormal basis on $T_p\mathbb{H}^n$ and $T_q\mathbb{H}^n$, there exists one and only isometry sending p to q and the basis of $T_p\mathbb{H}^n$ to the one of $T_q\mathbb{H}^n$.*

In particular, hyperbolic space is homogeneous and isotropic. We will denote by G the isometry group of \mathbb{H}^n .

Another remark on \mathbb{H}^n is that, for having negative sectional curvature and as a consequence of Hadamard's theorem, there are no conjugate points. Therefore it is diffeomorphic to euclidean space. Concretely, if $\exp : T_p\mathbb{H}^n \rightarrow \mathbb{H}^n$ is the exponential

map centered at a point p in \mathbb{H}^n , then \exp is a global diffeomorphism. Moreover, given an r -dimensional linear subspace V of $T_p\mathbb{H}^n$, the exponential map sends V to a totally geodesic r -dimensional submanifold of \mathbb{H}^n . These submanifolds are called *geodesic r -planes*. With the metric induced by the ambient, each of these r -planes L_r is isometric to \mathbb{H}^r . Given two r -planes, clearly exists an isometry of \mathbb{H}^n sending one to the other.

The fundamental difference between hyperbolic geometry and euclidean or spherical geometries is the fact that two hyperplanes in \mathbb{H}^n can be *generically* disjoint. In the sphere \mathbb{S}^n , two equators always intersect and, even if in \mathbb{R}^n two hyperplanes can be disjoint, we can always slightly move one of them to make them intersect. On the other hand, two hyperplanes in \mathbb{H}^n having a common perpendicular geodesic never intersect. This geodesic gives the minimum distance between the hyperplanes. If we move slightly one of the hyperplanes, the distance varies continuously and so they keep disjoint. Two hyperplanes with a common perpendicular are called *ultraparallel*. There is a limit case in which two hyperplanes are disjoint but at distance 0, that is infinitely close to intersect. In this case there is no common perpendicular and the hyperplanes are called *parallel*.

Through the exponential map one can send polar coordinates from T_pM to \mathbb{H}^n . We get the so-called *geodesic polar coordinates* in which the metric of \mathbb{H}^n is written

$$ds^2 = dr^2 + \sinh^{n-1} r du^2 \tag{1.1}$$

where r is the distance to p and du^2 is the metric of the unit sphere in $T_p\mathbb{H}^n$. To see this, it is enough to recall that the Jacobi field that is null in p and orthogonal to the radial geodesic has norm $\sinh r$ (cf.[dC92, p.113]). Thus, for instance, a circle C of radius R in \mathbb{H}^2 has length $2\pi \sinh R$ and bounds a disk of area $2\pi(\cosh R - 1)$. A simple computation shows that the geodesic curvature of C is constant $\coth R$. Note that it is always greater than 1. It becomes clear that a geodesic line is not approximated by circles. This is another characteristic property of hyperbolic geometry. If we fix a point of C and we make the center go infinitely away, we get a curve of constant geodesic curvature 1 called *horocycle*.

There is still another class of curves in \mathbb{H}^2 with constant geodesic curvature. For an oriented line L take, for every point $p \in \mathbb{H}^2$, the (signed) distance r from p to L and the point $x \in L$ where this distance is attained. In these coordinates, the area element of hyperbolic plane is

$$ds^2 = dr^2 + \cosh^2 r dx.$$

This is also seen via Jacobi fields. The curves $r \equiv \text{constant}$ are called *equidistants*. It is a computation to see that they have constant geodesic curvature $\tanh r$, and thus lower than 1.

Therefore, hyperbolic geometry includes four special types of curves: geodesics, circles, horocycles and equidistants. In higher dimensions one has four kinds of hypersurfaces with constant normal curvature λ , called *λ -hyperplanes*: geodesic hyperplanes for $\lambda = 0$, metric spheres for $\lambda > 1$, horospheres for $\lambda = 1$ and equidistant hypersurfaces for $\lambda < 1$. Again, horospheres are limits of spheres and equidistants are at constant

distance from some geodesic hyperplane. We only consider positive values of λ since the normal curvature changes its sign when changing the unit normal vector.

Sometimes we will be interested in convex subsets of \mathbb{H}^n . Naturally we will say that a set $Q \subset \mathbb{H}^n$ is *convex* if for any pair of points in Q the geodesic segment joining them is contained in Q . One can also define convexity by imposing that through every point in the boundary of Q passes some hyperplane leaving Q at one side. A domain with smooth boundary is convex if the normal curvature of its boundary is everywhere non-negative with respect to the inner normal. Thus, for instance, a λ -hyperplane bounds a convex region.

We will also be interested in stronger notions of convexity.

Definition 1.1.2. A set $Q \subset \mathbb{H}^n$ is called *λ -convex* if every point in the boundary is contained in some λ -hyperplane leaving Q in its convex side.

When the boundary is differentiable, the latter condition is equivalent to have all the normal curvatures with respect to the inner normal greater than λ . A λ -hyperplane is clearly the boundary of a λ -convex region.

The λ -convex sets were studied in [GR99, BGR01, BM02]. There, one deals with sequences of such sets growing to fill the whole space. It is easily seen that for $\lambda > 1$, there are not arbitrarily big λ -convex sets. Therefore, we will be mainly interested in the cases $\lambda \leq 1$. When $\lambda = 1$, 1-convex sets are usually called *h -convex*.

In order to compute, the classical formulas of hyperbolic trigonometry will be very useful. Let a, b and c be the sides of a geodesic triangle in \mathbb{H}^n and let, respectively, α, β and γ be the inner opposite angles. The following equalities then hold (cf. [Rat94])

$$\cosh a = \cosh b \cosh c - \sinh b \sinh c \cos \alpha,$$

$$\frac{\sinh a}{\sin \alpha} = \frac{\sinh b}{\sin \beta} = \frac{\sinh c}{\sin \gamma}, \tag{1.2}$$

$$\sinh a \cos \beta = \cosh b \sinh c - \sinh b \cosh c \cos \alpha.$$

1.1.2 Moving frames

In order to carry out the computations of integral geometry, the most useful method is that of the moving frames. The most elegant formulation of this method uses the language of principal bundles. For this, and because it allows us to work without any model, we study the frame bundle of \mathbb{H}^n . This bundle will be identified to the isometry group.

Consider $\mathcal{F}(\mathbb{H}^n)$, the bundle of orthonormal frames of \mathbb{H}^n . These frames are denoted by $g = (g_0; g_1, \dots, g_n) \in \mathcal{F}(\mathbb{H}^n)$ being g_0 a point in \mathbb{H}^n and g_1, \dots, g_n an orthonormal basis of $T_{g_0}\mathbb{H}^n$. Concretely

$$\pi : \mathcal{F}(\mathbb{H}^n) \rightarrow \mathbb{H}^n$$

is a principal bundle with structural group $O(n)$. The action on the right of this group is

$$R : \mathcal{F}(\mathbb{H}^n) \times O(n) \longrightarrow \mathcal{F}(\mathbb{H}^n) \quad (1.3)$$

$$((g_0; g_1, \dots, g_n), u) \longmapsto (g_0; g_1 u_1^1 + \dots + g_n u_1^n, \dots, g_1 u_n^1 + \dots + g_n u_n^n). \quad (1.4)$$

Recall that the frames $g \in \mathcal{F}(\mathbb{H}^n)$ can be thought of as linear isometries

$$g : \mathbb{R}^n \rightarrow T_{\pi(g)}\mathbb{H}^n.$$

This way $R(g, u) = g \circ u$. The canonical form θ of $\mathcal{F}(\mathbb{H}^n)$ takes values in \mathbb{R}^n and is given by

$$\theta(X) = g^{-1} d\pi(X) \quad X \in T_g \mathcal{F}(\mathbb{H}^n).$$

The i -th component of θ is a real-valued form and will be denoted ω_0^i . Given a (local) section $g : \mathbb{H}^n \rightarrow \mathcal{F}(\mathbb{H}^n)$, for every vector v tangent to \mathbb{H}^n

$$g^* \omega_0^i(v) = \omega_0^i(dgv) = \langle v, g_i \rangle.$$

Consider now the infinitesimal action σ mapping every element X of $\mathfrak{o}(n)$, Lie algebra of $O(n)$, to a field $\sigma(X)$ on $(\mathcal{F}(\mathbb{H}^n))$ defined by

$$\sigma(X)_g := dR_{(g,e)}(0, X) \quad \forall g \in \mathcal{F}(\mathbb{H}^n)$$

That is, σ is a mapping from $\mathfrak{o}(n)$ to the vertical fields (tangent to the fibers) of $\mathcal{F}(\mathbb{H}^n)$. The fields thus obtained are called *fundamental fields*. Recall that $\mathfrak{o}(n)$ consists of the antisymmetric matrices. Consider the matrix X_i^j with zeros at all the positions except from $(X_i^j)_i^j = 1$ and $(X_i^j)_j^i = -1$ (here and in the following A_i^j stands for the position in the row i and the column j of the matrix A). Define the following field on $\mathcal{F}(\mathbb{H}^n)$

$$v_i^j = \sigma(X_i^j).$$

Since $\{X_i^j | 1 \leq i < j \leq n\}$ is a basis of $\mathfrak{o}(n)$, the fields $\{v_i^j | 1 \leq i < j \leq n\}$ are linearly independent at every point. Note that $v_i^j = -v_j^i$. One can geometrically think of v_i^j as the tangent vector of the curve of frames in a point having all the vectors fixed except from g_i and g_j . Concretely, v_i^j is the tangent vector to the curve $g(t) = (g_1, \dots, g_n)$ in $\mathcal{F}(\mathbb{H}^n)$ where

$$g_r(t) \equiv g_r \quad r \neq i, j \quad \begin{aligned} g_i(t) &= \cos t g_i + \sin t g_j \\ g_j(t) &= -\sin t g_i + \cos t g_j. \end{aligned}$$

A connection in the principal bundle π is a form ω taking values in $\mathfrak{o}(n)$ such that $\omega(\sigma(X)) = X$ and $\omega(dR_u X) = Ad(u^{-1})\omega(X)$. Such a form determines a (Koszul) connection ∇ in \mathbb{H}^n . If $g : U \rightarrow \mathcal{F}(\mathbb{H}^n)$ is a local section of π , then

$$\omega_i^j(dgv) = \langle \nabla_v g_j, g_i \rangle$$

where $\langle \cdot, \cdot \rangle$ is the metric on \mathbb{H}^n . Note that the coefficients ω_i^j , for $1 \leq i, j \leq n$, are real-valued forms $\mathcal{F}(\mathbb{H}^n)$ such that $\omega_i^j = -\omega_j^i$. We choose the form ω which determines the Levi-Civita connection ∇ in \mathbb{H}^n .

The connection form ω determines a distribution \mathcal{H} complementary to the *vertical* part $\mathcal{V} = T_g\pi^{-1}(\pi(g))$ which is called the *horizontal* part; a vector X is horizontal, and belongs to \mathcal{H} , if and only if $\omega(X) = 0$. The horizontal vectors are tangent to the parallel transport of a frame along a curve in \mathbb{H}^n . On the other hand, each vector $x \in \mathbb{R}^n$ has an associated field $B(x)$ on $\mathcal{F}(\mathbb{H}^n)$, called *basic field*, which is the only horizontal field such that $d\pi B(x)_g = g(x) \in T_{\pi(g)}\mathbb{H}^n$. Define, for $i = 1, \dots, n$, the following linearly independent system of basic fields

$$v_0^i = B(e_i).$$

It is convenient to define also $v_i^0 = v_0^i$. Geometrically v_0^i is the tangent vector to the curve of frames obtained by parallel transport of the basis $\{g_j\}$ along the geodesic starting at g_0 with tangent vector g_i .

Restricting the indices to $0 \leq i < j \leq n$ the system $\{v_i^j\}$ becomes a basis of $T_g\mathcal{F}(\mathbb{H}^n)$ at every frame g . Besides, ω_i^j is the dual basis of v_i^j .

The structure equations of the principal bundle π are

$$d\theta = -\omega \wedge \theta$$

$$d\omega = -[\omega, \omega] + \Omega$$

Which must be understood this way: for every pair $X, Y \in T_g\mathcal{F}(\mathbb{H}^n)$

$$d\theta(X, Y) = -\omega(X) \cdot \theta(Y) + \omega(Y) \cdot \theta(X)$$

$$d\omega(X, Y) = -\omega(X) \cdot \omega(Y) + \omega(Y) \cdot \omega(X) + \Omega(X, Y)$$

where \cdot stands for the ordinary matrix product and the elements of \mathbb{R}^n are columns. In our case, since the sectional curvatures are -1 , we have ([KN96a, p. 204]) $\Omega = -\theta \wedge \theta$; that is

$$\Omega(X, Y) = \theta(Y) \cdot \theta(X)^t - \theta(X) \cdot \theta(Y)^t$$

The fact that \mathbb{H}^n has constant curvature allows us to endow $\mathcal{F}(\mathbb{H}^n)$ with a Lie group structure. This is done through proposition 1.1.1. Fix a point $e_0 \in \mathbb{H}^n$ and an orthonormal basis (e_1, \dots, e_n) of $T_{e_0}\mathbb{H}^n$; that is, fix a frame $e = (e_0; e_1, \dots, e_n) \in \mathcal{F}(\mathbb{H}^n)$. Every frame $g \in \mathcal{F}(\mathbb{H}^n)$ can be associated to the only isometry which maps e to g . Thus, the bundle $\mathcal{F}(\mathbb{H}^n)$ is identified to G , the isometry group of \mathbb{H}^n .

The product operation of G can be thought of as a left action of G on the frame bundle. Thinking of the elements of $\mathcal{F}(\mathbb{H}^n)$ as isometries $h : \mathbb{R}^n \rightarrow T_{\pi(h)}\mathbb{H}^n$

$$\begin{aligned} G \times \mathcal{F}(\mathbb{H}^n) &\longrightarrow \mathcal{F}(\mathbb{H}^n) \\ (g, h) &\longmapsto dg \circ h \end{aligned}$$

with $dg \circ h : \mathbb{R}^n \rightarrow T_{g(h_0)}\mathbb{H}^n$. Both ω and θ are invariant under this action since the metric of \mathbb{H}^n is invariant under G . Thus, fundamental and basic fields are left-invariant. In other words, if \mathfrak{g} is the Lie algebra of G , then

$$\sigma : \mathfrak{o}(n) \rightarrow \mathfrak{g} \quad \text{and} \quad B : \mathbb{R}^n \rightarrow \mathfrak{g}$$

are injective morphisms (or inclusions) of Lie algebras. These inclusions allow us to think of ω and θ as forms on G taking values in \mathfrak{g} (the one takes values in the vertical part and the other in the horizontal one). Define a new form on G

$$\bar{\omega} = B \circ \theta + \sigma \circ \omega$$

taking values in \mathfrak{g} . This form is left-invariant and is the identity at the neuter element $e \in G$. Therefore, $\bar{\omega}$ is the Maurer-Cartan form of G . The structure equation of Lie groups states

$$d\bar{\omega} + [\bar{\omega}, \bar{\omega}] = 0$$

which, together with the structure equations of θ and ω , allows us to compute the Lie bracket of \mathfrak{g} . For $X, Y \in \mathfrak{g}$

$$\begin{aligned} [X, Y] &= [\bar{\omega}(X), \bar{\omega}(Y)]_e = -d\bar{\omega}(X, Y) = -\sigma(d\omega(X, Y)) - B(d\theta(X, Y)) = \\ &= \sigma([\omega(X), \omega(Y)]) + \sigma(\theta(X) \cdot \theta(Y)^t - \theta(Y) \cdot \theta(X)^t) + \\ &\quad + B(\omega(X) \cdot \theta(Y) - \omega(Y) \cdot \theta(X)). \end{aligned}$$

That is, for fundamental and basic fields, if $X, Y \in \mathfrak{o}(n)$ and $x, y \in \mathbb{R}^n$

$$\begin{aligned} [\sigma(X), \sigma(Y)] &= \sigma[X, Y], & [\sigma(X), B(y)] &= B(X \cdot y) \\ [B(x), B(y)] &= \sigma(xy^t - yx^t). \end{aligned} \tag{1.5}$$

In particular, we know the bracket for the fields v_i^j with $0 \leq i \neq j \leq n$.

Lemma 1.1.2. *The Lie bracket of \mathfrak{g} is given by*

$$\begin{aligned} [v_i^j, v_j^s] &= v_i^s \quad \text{for } i \neq j \neq s \\ [v_i^j, v_r^s] &= 0 \quad \text{for } i < j < r < s. \end{aligned}$$

Proof. It is easy to check knowing the bracket of $\mathfrak{o}(n)$ and using (1.5) besides of $v_i^j = -\epsilon(i)\epsilon(j)v_j^i$. \square

With all this we can obtain the Killing form $K_{\mathfrak{g}}$ of \mathfrak{g} . Recall that this is defined to be $K_{\mathfrak{g}}(X, Y) = \text{tr}(\text{ad}_X \circ \text{ad}_Y)$ and it is bi-invariant. A first remark is that, as a general fact on symmetric spaces, the horizontal and vertical subspaces of \mathfrak{g} are orthogonal with respect to $K_{\mathfrak{g}}$ (cf. [Hel01]). The restriction to the vertical subspace is, up to a

constant, the Killing form of $\mathfrak{o}(n)$ given by $K_{\mathfrak{o}(n)}(X, Y) = (n - 2)\text{tr}XY$ for $X, Y \in \mathfrak{o}(n)$ (cf. [KN96b, p.266]).

$$\begin{aligned} K_{\mathfrak{g}}(\sigma(X), \sigma(Y)) &= \text{tr}(\text{ad}_{\sigma(X)}\text{ad}_{\sigma(Y)}|_{\mathcal{V}}) + \text{tr}(\text{ad}_{\sigma(X)}\text{ad}_{\sigma(Y)}|_{\mathcal{H}}) \\ &= K_{\mathfrak{o}(n)}(X, Y) + \text{tr}(B(x) \mapsto B(XYx)) = \\ &= (n - 2)\text{tr}(XY) + \text{tr}(XY) = (n - 1)\text{tr}(XY) \\ &= \frac{n - 1}{n - 2}K_{\mathfrak{o}(n)}(X, Y). \end{aligned}$$

It remains to determine the restriction to the horizontal part. A general property of the Killing form is $K(X, [Y, Z]) = K(Y, [Z, X])$ (cf.[Hel01]). Thus, for $Y \in \mathfrak{o}(n)$ and $x, z \in \mathbb{R}^n$

$$\begin{aligned} K_{\mathfrak{g}}(B(x), B(Yz)) &= K_{\mathfrak{g}}(B(x), [\sigma(Y), B(z)]) = K_{\mathfrak{g}}(\sigma(Y), [B(z), B(x)]) = \\ &= K_{\mathfrak{g}}(\sigma(Y), \sigma(zx^t - xz^t)) = (n - 1)\text{tr}(Y(zx^t - xz^t)) = 2(n - 1)(Yz)^t x. \end{aligned}$$

Since every vector of \mathbb{R}^n can be written as Yz , we have seen that the restriction of $K_{\mathfrak{g}}$ to the horizontal part is, up to a constant, the metric of \mathbb{H}^n . Since the vertical and horizontal subspaces are orthogonal, the Killing form of \mathfrak{g} is determined; namely

$$K_{\mathfrak{g}}(X, Y) = \frac{n - 1}{n - 2}K_{\mathfrak{o}(n)}(\omega(X), \omega(Y)) + 2(n - 1)\langle d\pi(X), d\pi(Y) \rangle \quad X, Y \in \mathfrak{g}$$

where $\langle \cdot, \cdot \rangle$ is the metric on \mathbb{H}^n . That is,

$$K_{\mathfrak{g}} = 2(n - 1) \sum_{i=1}^n \omega_0^i \otimes \omega_0^i - 2(n - 1) \sum_{1 \leq i < j \leq n} \omega_i^j \otimes \omega_j^i.$$

In particular $K_{\mathfrak{g}}$ is a semi-riemannian metric on G , bi-invariant, non-degenerate and with signature n . Later we will see that G does not admit a bi-invariant positive (nor negative) definite metric.

However, it is convenient to take the following metric in G

$$\langle X, Y \rangle := -\frac{1}{2(n - 1)}K_{\mathfrak{g}}(X, Y) \quad X, Y \in \mathfrak{g}. \quad (1.6)$$

This way, the basis $\{v_i^j\}_{i < j}$ of \mathfrak{g} is orthonormal with respect to $\langle \cdot, \cdot \rangle$. Indeed, being $\epsilon(i) = 1$ for $i \neq 0$ and $\epsilon(0) = -1$,

$$\langle v_i^j, v_r^s \rangle = \epsilon(i)\delta_{ir}\delta_{js} \quad i < j \quad i \quad r < s.$$

1.1.3 Models

Hyperboloid model.

The hyperboloid model, even if it will not be strictly necessary at any moment, can be useful to get a concrete vision of hyperbolic space.

Consider the $(n + 1)$ -dimensional Minkowski space. That is, consider in \mathbb{R}^{n+1} the following Lorentz metric

$$L(x, y) = -x_0y_0 + x_1y_1 + \cdots + x_ny_n.$$

A vector $v \in \mathbb{R}^{n+1}$ is called *time-like* if $L(v, v) < 0$. When $L(v, v) > 0$ it is called *space-like*. A vector v such that $L(v, v) = 0$ is *light-like*. The set of light-like vectors is the *light cone*. Similarly, a linear subspace of \mathbb{R}^{n+1} is *time-like* if it contains time-like vectors, it is *space-like* if it contains only space-like vectors, and it is *light-like* if it contains only light-like and space-like vectors. In the latter case the subspace is tangent to the light cone.

The *hyperboloid model* of hyperbolic space \mathbb{H}^n is the set of vectors with squared norm -1 having the first component positive

$$\mathbb{H}^n = \{v \in \mathbb{R}^{n+1} \mid L(v, v) = -1 \text{ i } v_0 > 0\}.$$

The tangent vectors to \mathbb{H}^n in a point p are orthogonal respect to L to the vector $p \in \mathbb{R}^{n+1}$; i.e. $T_p\mathbb{H}^n = (p)^\perp$. This implies that the restriction of L to the tangent space of \mathbb{H}^n at every point is positive definite. This way we endow \mathbb{H}^n of a riemannian structure. It can be checked that this manifold has constant curvature -1 and is therefore a model for hyperbolic space.

The connection ∇ of \mathbb{H}^n is given by $\bar{\nabla}$, the usual connection of \mathbb{R}^{n+1} , through

$$(\bar{\nabla}_X Y)_p = (\nabla_X Y)_p - L(p, (\bar{\nabla}_X Y)_p) \cdot p \quad X, Y \in \mathfrak{X}(\mathbb{H}^n) \quad p \in \mathbb{H}^n. \quad (1.7)$$

That is, ∇ is the L -orthogonal projection of $\bar{\nabla}$ to \mathbb{H}^n . Therefore, the geodesics of \mathbb{H}^n are intersections of linear 2-planes in \mathbb{R}^{n+1} with \mathbb{H}^n . In general, the intersection of a linear subspace of \mathbb{R}^{n+1} with \mathbb{H}^n is a totally geodesic submanifold.

The hyperboloid model gives a representation of G , isometry group of \mathbb{H}^n , as a subgroup of the linear group. Indeed, the isometry group of \mathbb{H}^n is

$$G = \{g \in Gl(n + 1) \mid g^t J g = J, g_0^0 > 0\}$$

$$\text{on } J = \begin{pmatrix} -1 & 0 & \dots & 0 \\ 0 & 1 & \dots & 0 \\ \vdots & \vdots & \ddots & \vdots \\ 0 & 0 & \dots & 1 \end{pmatrix}.$$

With this representation, the identification between G and $\mathcal{F}(\mathbb{H}^n)$ is very simple. Indeed, fix in \mathbb{H}^n the frame given by the canonical basis of \mathbb{R}^{n+1} . For every matrix in G , the columns represent the image of this frame. So, every matrix in G is identified with the frame of $\mathcal{F}(\mathbb{H}^n)$ given by its columns.

If a curve $g(t) \subset G$ passes by e at $t = 0$, then

$$\dot{g}^t(0)J + J\dot{g}(0) = 0.$$

We deduce that the Lie algebra of G consists of the antisymmetric matrices multiplied by J

$$\mathfrak{g} = \{V \in M_{n+1}(\mathbb{R}) \mid VJ + JV^t = 0\}.$$

With this representation, it is easy to check that for every pair $u, v \in \mathfrak{g}$, the metric (1.6) is

$$\langle u, v \rangle = \frac{1}{2}(-L(u^0, v^0) + L(u^1, v^1) + \cdots + L(u^n, v^n))$$

where u^i and v^i stand for the i -th columns of u and v .

The projective model.

The projective model is the projectivization of the hyperboloid. In this model, geodesics look as straight lines and this makes it very useful when dealing with qualitative questions; not when computing.

Projectivize \mathbb{R}^{n+1} . The Lorentz metric L becomes a non-degenerate quadric C . Thus, the points in \mathbb{H}^n are those x such that $C(x, x) < 0$. The conic $\{C(x, x) = 0\}$ is called the *sphere at infinity* and its points are called *ideal* points. The totally geodesic submanifolds of \mathbb{H}^n are here intersections of projective manifolds. The isometries are given by projective transformations preserving C . Note that such transformations preserve automatically the interior since the exterior of a conic is topologically non-orientable. Obviously, this model is also a Riemann manifold but we will not need to know explicitly its metric (which can be found for instance in [LS00]).

Since all the non-degenerate quadrics are projectively equivalents, the projective model of hyperbolic space is the interior of any non-degenerate conic in \mathbb{RP}^n . We will usually take an affine chart in which the conic appears as a sphere centered at the origin.

1.2 Mean curvature integrals

Here we define the main object of study of this text. We are interested in mean curvature integrals of hypersurfaces in \mathbb{H}^n . However, we will also deal with hypersurfaces in other spaces. So, we give the definitions for arbitrary Riemann manifolds.

Let N be an n -dimensional Riemann manifold. Unless otherwise stated, we will always assume that all the objects are infinitely differentiable. Let $S \subset N$ be a hypersurface. At every point $p \in S$, given a unit vector $\mathfrak{n} \perp T_p S$ the second fundamental form \mathbb{I} of S is

$$\mathbb{I}(X, Y) = \langle \nabla_X Y, \mathfrak{n} \rangle \quad X, Y \in T_p S.$$

where ∇ denotes the connection in N . It is a symmetric bilinear form on $T_p S$. Thus, it has an orthonormal basis of eigenvectors. The corresponding eigenvalues k_1, \dots, k_n are called *principal curvatures* of p . Define the *i -th mean curvature* function of S to be

$$\sigma_i = \frac{f_i(k_1, \dots, k_{n-1})}{\binom{n-1}{i}}$$

where f_r is the i -th symmetric elementary polynomial. They are also defined by

$$\det(\mathbb{I} + tId) = \sum_{j=0}^r \binom{n-1}{j} \sigma_j t^j.$$

The following property is very used in integral geometry.

Proposition 1.2.1. [LS82, p. 559],[Teu86] For every linear subspace l of dimension i of $T_x S$, denote $\mathbb{I}|_l$ the restriction of \mathbb{I} to l . Then,

$$\int_{G(i, T_x N)} \det(\mathbb{I}|_L) dL = \text{vol}(G(i, n-1)) \sigma_i$$

We will usually refer to the determinant of the restriction $\mathbb{I}|_L$ as the *normal curvature* in the direction L . Thus, the mean curvature is the mean value of the normal curvatures. These normal curvatures have a geometric meaning in terms of intersections. The following theorem is a generalization of the classical Meusnier's theorem.

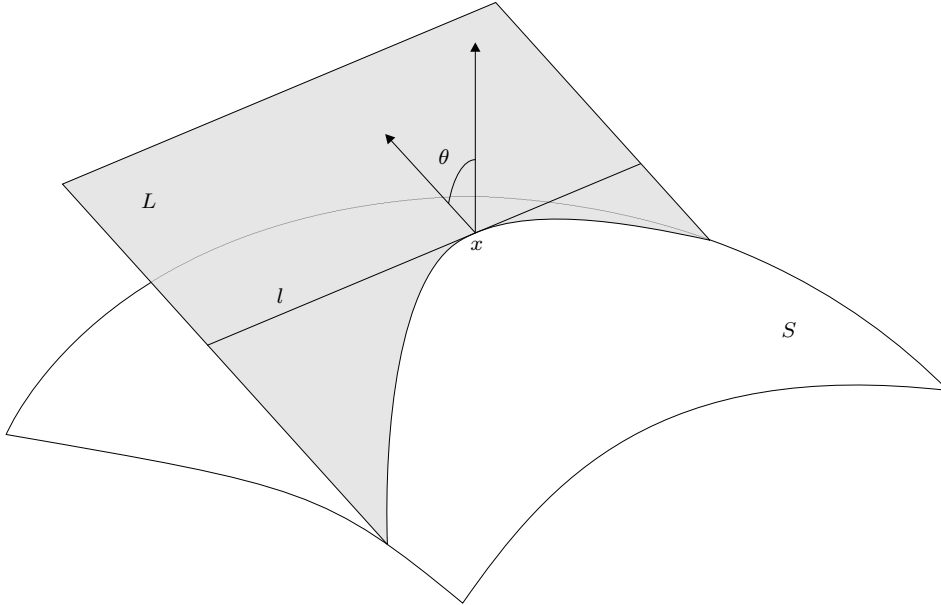

Figure 1.1: Meusnier's theorem

Theorem 1.2.2. [LS82, p. 561] If L is an $(r+1)$ -dimensional affine plane intersecting a hypersurface $S \subset \mathbb{R}^n$ in x , then the normal curvature of S at x in the direction $l = T_x S \cap L$ is

$$K(l) = \det(\mathbb{I}|_l) = \cos^r \theta \cdot K(L \cap S)$$

where θ is the angle in x between the (chosen) unit normal vectors of S and $l \subset L$, and $K(L \cap S)$ is the Gauss curvature in x of $L \cap S$ as a hypersurface of $L \cong \mathbb{R}^r$.

Therefore, the normal curvature is the Gauss curvature of the intersection with an orthogonal affine plane.

The latter theorem holds for hypersurfaces S in any Riemann manifold N if one changes L by $\exp_x L$ for some linear subspace $L \subset T_x N$. Indeed, S can be locally copied to a hypersurface of $T_x N$ through \exp_x . It is easy to check that \exp_x does not change the second fundamental form of S in x . Since $T_x N$ is euclidean we will be in conditions to apply the last theorem.

This theorem allows us to prove that the projective model is faithful with respect to the sign of normal curvatures.

Proposition 1.2.3. *Let $S \subset \mathbb{H}^n$ be an oriented hypersurface in the projective model. Let \mathbf{n} and \mathbf{n}' be the unit normal vectors to $T_p S$ in a point p of S with respect to the euclidean and hyperbolic metrics respectively and according to the orientation. Then, for every direction in $T_p S$, the normal curvature of S with these normal vectors has the same sign with respect to both metrics.*

Proof. Let us start with the euclidean metric. Intersect with an affine plane L containing p and \mathbf{n} . The curvature of the intersection curve $L \cap S$ is the normal curvature of S . With respect to the hyperbolic metric, L is still totally geodesic. The Meusnier theorem states that the (hyperbolic) normal curvature of S is a positive multiple of the curvature of $L \cap S$ since $\langle \mathbf{n}, \mathbf{n}' \rangle > 0$. □

Next we define the mean curvature integrals which are the main object of study in this text.

Definition 1.2.1. Let N be a Riemann manifold and $S \subset N$ be a compact hypersurface, possibly with boundary, oriented with a unit normal. The i -th mean curvature integral of S is

$$M_i(S) = \int_S \sigma_i(p) dp$$

where dp is the volume element of S . Note that $M_0(S)$ is the volume of S and $M_{n-1}(S)$ is the integral of the Gauss curvature (or *total curvature*, or even *curvatura integra*) of S .

As an example, the mean curvature integrals in \mathbb{S}^n , \mathbb{R}^n and \mathbb{H}^n of a sphere $S(R)$ of radius R are

$$M_i(S(R)) = O_{n-1} \cos^i R \sin^{n-i-1} R \quad \text{in } \mathbb{S}^n \quad (1.8)$$

$$M_i(S(R)) = O_{n-1} R^{n-i-1} \quad \text{in } \mathbb{R}^n \quad (1.9)$$

$$M_i(S(R)) = O_{n-1} \cosh^i R \sinh^{n-i-1} R \quad \text{in } \mathbb{H}^n \quad (1.10)$$

In constant curvature spaces, the mean curvature integrals appear, for instance, in the Steiner formula for the volume of parallel hypersurfaces. Let S be a compact hypersurface C^2 differentiable of a space of constant curvature k , oriented through a unit normal \mathbf{n} . Consider the map sending $x \in S$ to $\gamma(\epsilon)$ where $\gamma(t)$ is the geodesic

starting at x with tangent n . For small enough ϵ , the image of S through this mapping is a hypersurface S_ϵ of \mathbb{H}^n called *parallel* at distance ϵ . The Steiner (cf.[Gra90]) formula expresses, for small enough ϵ , the volume of S_ϵ as a homogeneous polynomial in $\cos(\sqrt{k}\epsilon)$ and $\sin(\sqrt{k}\epsilon)/\sqrt{k}\epsilon$ having the mean curvature integrals of S as coefficients

$$\text{vol}(S_\epsilon) = \sum_{i=0}^{n-1} \binom{n-1}{i} M_i(S) \cos^{n-i-1}(\sqrt{k}\epsilon) \frac{\sin^i(\sqrt{k}\epsilon)}{(\sqrt{k}\epsilon)^i}. \quad (1.11)$$

For $k < 0$ it must be taken $\cos(\sqrt{k}\epsilon) = \cosh(\sqrt{-k}\epsilon)$ and $\sin(\sqrt{k}\epsilon)/\sqrt{k}\epsilon = \sinh(\sqrt{-k}\epsilon)$. For $k = 0$ take $\sin(\sqrt{k}\epsilon)/\sqrt{k}\epsilon = \epsilon$.

A generalization of this formula expresses $M_i(S_\epsilon)$ in terms of $M_j(S)$. This formula was discovered by Santaló in [San50]. The prove given there was not completely correct in the hyperbolic case since it made use of osculating circles. In hyperbolic geometry, osculating circles exist only where a curve has curvature greater than 1. Anyway, we next give another elementary proof.

Proposition 1.2.4. *If S_ϵ is the parallel hypersurface to $S \subset \mathbb{H}^n$, then*

$$\binom{n-1}{i} M_i(S_\epsilon) = \sum_{k=0}^{n-1} \binom{n-1}{k} M_k(S) \phi_{ik}(\epsilon) \quad (1.12)$$

where

$$\phi_{ik}(\epsilon) = \sum_{h=\max(0, i+k-n+1)}^{\min(i, k)} \binom{n-k-1}{i-h} \binom{k}{h} \sinh^{i+k-2h} \epsilon \cosh^{n-1-i-k+2h} \epsilon.$$

Proof. For small $t > 0$ we have

$$\begin{aligned} \text{vol}(S_{\epsilon+t}) &= \sum_{i=0}^{n-1} \binom{n-1}{i} M_i(S) \cosh^{n-i-1}(\epsilon+t) \sinh^i(\epsilon+t) = \\ &= \sum_{i=0}^{n-1} \binom{n-1}{i} M_i(S_\epsilon) \cosh^{n-i-1}(t) \sinh^i(t). \end{aligned}$$

We finish substituting

$$\cosh(\epsilon+t) = \cosh \epsilon \cosh t + \sinh \epsilon \sinh t \quad \sinh(\epsilon+t) = \cosh \epsilon \sinh t + \sinh \epsilon \cosh t$$

and equating the coefficients of the two resulting homogeneous polynomials in $\cosh \epsilon$ and $\sinh \epsilon$. \square

Remark. For any abstract smooth manifold S and an immersion $i : S \rightarrow N$, one endows S with the pull-back of the metric on N . Then, there is no problem on identifying locally the neighborhoods $p \in U \subset S$ with their image $i(U) \subset N$. Thus, all what has been said for hypersurfaces stands also for codimension 1 immersions.

The mean curvature integrals are directly related to the so-called Quermassintegrale of convex sets of euclidean space. For a convex domain $Q \subset \mathbb{R}^n$, the *Quermassintegrale* are defined to be, up to a constant factor, the mean value of the volumes of the orthogonal projections π_L of the convex domain onto the linear subspaces $L \in G(n-r, n)$,

$$W_r(Q) = \frac{(n-r) \cdot O_{n-1}}{n \cdot O_{n-r-1} \text{vol}(G(n-r, n))} \int_{G(n-r, n)} \text{vol}(\pi_L(Q)) dL. \quad (1.13)$$

where dL is a measure in $G(n-r, n)$ invariant under rotations. One also defines usually $W_0(Q) = \text{vol}(Q)$ and $W_n(Q) = O_{n-1}\chi(Q)/n$. When the boundary ∂Q is smooth, the Quermassintegrale are directly linked to the mean curvature integrals through the so-called *Cauchy formula*

$$M_r(\partial Q) = nW_{r+1}(Q). \quad (1.14)$$

However, this point of view is nonsense in hyperbolic space (and also in \mathbb{S}^n). One should start choosing some origin $p \in \mathbb{H}^n$ and then projecting onto totally geodesic submanifolds through p . But the result would depend on p , and thus, one would not even get an isometry invariant. In the next chapter we will give an invariant definition for the Quermassintegrale of a convex domain in \mathbb{H}^n that is related to the mean curvature integrals. Moreover, this definition will make sense for not necessarily convex domains with smooth boundary. Before, one has to study the spaces of geodesic planes of \mathbb{H}^n .

Chapter 2

Spaces of planes

2.1 Spaces of planes

In this section we study the spaces of totally geodesic planes of \mathbb{H}^n . They are homogeneous spaces of the isometry group G . These spaces do not admit any riemannian metric invariant under G . However, they can be endowed with a semi-riemannian invariant metric. The fact that these metric are not definite becomes a deep difference with euclidean and spherical geometries. Let us advance, for instance, that a bundle of ultra-parallel hyperplanes is a curve with time-like tangent in the space of hyperplanes. On the other hand, in chapter 3, when dealing with some questions on total curvature and total absolute curvature, the non-definiteness of these metrics will make things quite difficult.

We have already said that we call r -planes the complete r -dimensional totally geodesic submanifolds.

Definition 2.1.1. We call *space of r -planes of \mathbb{H}^n* the set of complete r -dimensional totally geodesic submanifolds of \mathbb{H}^n . We denote this space by \mathcal{L}_r .

Let us choose some r -plane in hyperbolic space; for instance $L_r^0 = \exp_{e_0} \langle e_1, \dots, e_r \rangle$. If $H_r \subset G$ is the subgroup of motions leaving L_r^0 invariant, we identify \mathcal{L}_r to the homogeneous space G/H_r trough the following bijection

$$\begin{aligned} G/H_r &\longrightarrow \mathcal{L}_r \\ g \cdot H_r &\longmapsto gL_r^0 = \exp_{g_0} \langle g_1, \dots, g_r \rangle. \end{aligned}$$

We have then a projection $\pi_r : G \longrightarrow \mathcal{L}_r$. The tangent space to a fiber of an r -plane L_r is

$$\mathfrak{h}_r = \langle v_i^j \mid 0 \leq i < j \leq r \text{ o } r < i < j \leq n \rangle.$$

On the other hand, the tangent space to \mathcal{L}_r in L_r is identified through $d\pi_r$ to

$$\mathfrak{m}_r = (\mathfrak{h}_r)^\perp = \langle v_i^j \mid 0 \leq i \leq r < j \leq n \rangle.$$

In particular we note that \mathcal{L}_r has dimension $(r+1)(n-r)$.

The space of lines in hyperbolic plane is a Möbius band. Indeed, they are parametrized in the following way: take some unit geodesic γ starting at the origin e_0 making an angle θ with the direction e_1 ; for every $\rho \in \mathbb{R}$ take the orthogonal line to γ in $\gamma(\rho)$. In this way, every line in \mathbb{H}^2 is given by the polar coordinates (ρ, θ) with $0 \leq \theta \leq \pi$ and $\rho \in \mathbb{R}$. But it is clear that the line $(\rho, 0)$ is identified to $(-\rho, \pi)$.

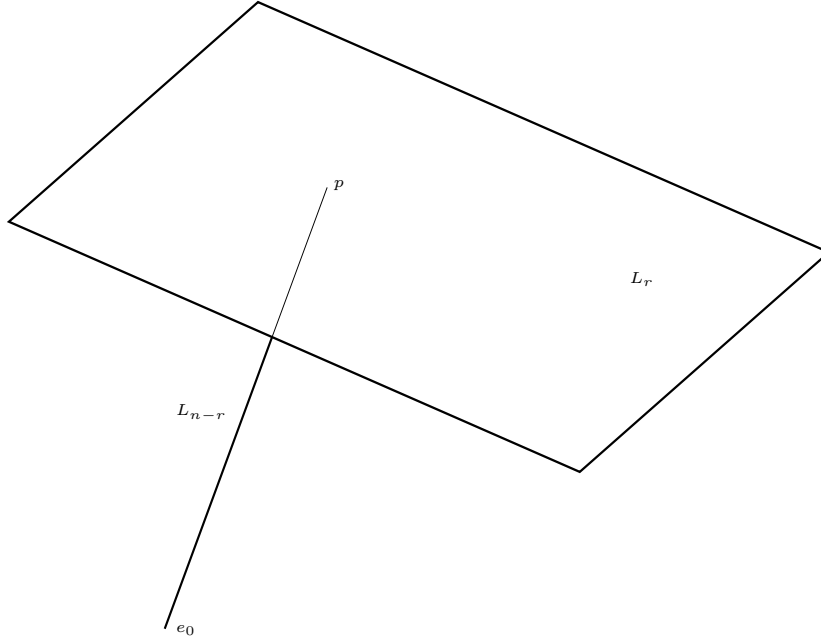

Figure 2.1: The space of planes is identified to the tautological fibre bundle

The same can be done to identify topologically \mathcal{L}_r . Note that given an r -plane L_r , there exists one and only one orthogonal $(n - r)$ -plane to L_r passing through the origin $e_0 \in \mathbb{H}^n$. This $(n - r)$ -plane intersects L_r at the minimum distance point from e_0 . Then, every element of \mathcal{L}_r is given by a couple (L_{n-r}, p) where L_{n-r} is an $(n - r)$ -plane through the origin and p is a point in L_{n-r} (figure 2.1). In other words, \mathcal{L}_r is identified to the tautological (or canonical) bundle of the Grassmannian $G(n - r, n)$ of $(n - r)$ -dimensional subspaces of $T_{e_0}\mathbb{H}^n$. Moreover, this identification is a diffeomorphism.

Remark. All that we have said so far about the planes in \mathbb{H}^n holds without change for the affine planes of \mathbb{R}^n . Concerning to \mathbb{S}^n , its spaces of planes are the usual Grassmannian manifolds. To be precise, an r -dimensional totally geodesic submanifold in \mathbb{S}^n (*geodesic r -plane*) is the intersection of the sphere with an $(r + 1)$ -dimensional linear subspace of \mathbb{R}^{n+1} . When no confusion is possible we will denote the space of r -planes of \mathbb{S}^n indistinctly by $G(r + 1, n + 1)$ or by \mathcal{L}_r . These are homogeneous spaces of $O(n + 1)$.

2.1.1 Invariant metrics and measures

Invariant metrics

When a group is acting on a manifold it is natural to endow this manifold with invariant objects under this action. For instance it is natural to look for invariant metrics which also define invariant measures. In our case, one would like to endow \mathcal{L}_r with a riemannian metric invariant under the action of G . It is easy to see that this is not possible.

Proposition 2.1.1. *The space of planes \mathcal{L}_r does not admit a riemannian metric invariant under the action of G .*

Proof. Consider two parallel r -planes. Take a 2-plane such that both r -planes intersect it orthogonally. We get a couple of parallel lines in \mathbb{H}^2 . If we take the projective model of \mathbb{H}^2 , we can find an isometry mapping these two lines to any other couple of parallel lines (figure 2.2). Indeed, the projective mappings preserving a conic act transitively on the triples of points. These isometries extend trivially to isometries of \mathbb{H}^n . Therefore, in a bundle of parallel r -planes, one can map any pair of r -planes to any other. This bundle is a curve in \mathcal{L}_r and a riemannian metric defines an arc length on this curve. But if the metric is invariant under G , any two of the arcs of this curve have the same length; a contradiction. \square

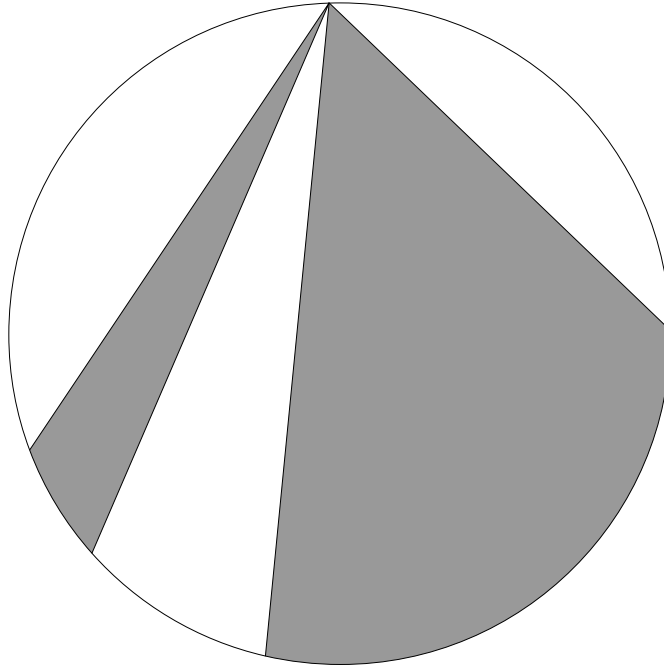

Figure 2.2: Equivalent pairs of parallel lines

Nevertheless, if the metric in \mathcal{L}_r were not supposed to be positive definite, instead of a contradiction one would arrive at the conclusion that the curve has a light-like

tangent vector. Next we find semi-riemannian metrics in \mathcal{L}_r invariant under G . This is immediate using the bi-invariant metric of G .

Proposition 2.1.2. *In \mathcal{L}_r there is a metric $\langle \cdot, \cdot \rangle_r$ that makes the projection $\pi_r : G \rightarrow \mathcal{L}_r$ be a semi-riemannian submersion. This metric is invariant and its pull-back through π is*

$$\pi_r^* \langle \cdot, \cdot \rangle_r = \sum_{1 \leq i \leq r < j \leq n} \omega_i^j \otimes \omega_i^j - \sum_{j=r+1}^n \omega_0^j \otimes \omega_0^j \quad (2.1)$$

Proof. The metric (2.1) is the restriction of the metric $\langle \cdot, \cdot \rangle$ of G to the subspace \mathfrak{m}_r (cf. (1.6)). Projecting it to \mathcal{L}_r through π we get a metric in \mathcal{L}_r which is well defined since (2.1) is right invariant and thus, constant on the fibres. By the left invariance of the metric of G , this metric on \mathcal{L}_r is invariant under the action of G . \square

Remark. On the other hand, the space of r -planes in \mathbb{S}^n , the grassmanian $G(r+1, n+1)$, does admit a riemannian metric invariant under the action of $O(n)$. This metric can be geometrically described by saying that the geodesics are bundles of r -planes contained in an $(r+1)$ -plane and containing an $(r-1)$ -plane.

Concerning the r -planes in \mathbb{R}^n , we will see below that it does not even admit an invariant semi-riemannian (non-degenerate) metric. This is essentially due to the fact that the isometry group of the euclidean space has a degenerate Killing form.

Next we prove that, up to scalar factors, $\langle \cdot, \cdot \rangle_r$ is the only semi-riemannian metric of \mathcal{L}_r invariant under the action of G . Moreover, we will have a more geometric understanding of it.

Recall that we have fixed an orthonormal frame e_1, \dots, e_n in a point e_0 and that we have chosen the r -plane $L_r^0 = \exp_{e_0}(\langle e_1, \dots, e_r \rangle)$. We have identified the tangent space at L_r^0 of the space of r -planes to the linear subspace \mathfrak{m}_r of \mathfrak{g} . We can split $T_{L_r^0} \mathcal{L}_r \equiv \mathfrak{m}_r$ in the vertical part V and the horizontal part (tangent to the base) H of the tautological bundle over $G(n-r, n)$

$$\mathfrak{m}_r = V \oplus H = \langle v_0^j \rangle \oplus \langle v_i^j \rangle \quad 1 \leq i \leq r < j \leq n$$

The vertical directions correspond to move L_r keeping it orthogonal to the same $(n-r)$ -plane, $L_{n-r} = \exp_{e_0}(e_{r+1}, \dots, e_n)$. The horizontal directions, correspond to rotate L_r around e_0 . In other words, the vertical part $V = \langle v_0^j \rangle$ is the tangent space to $L_{n-r} \equiv \mathbb{H}^{n-r}$, and the horizontal part $H = \langle v_i^j \rangle$ is the tangent space to the grassmannian of r -planes through e_0 which we denote $\mathcal{L}_{r[0]} (\equiv G(r, T_{e_0} \mathbb{H}^n))$. Through this identification, the metrics on L_{n-r} and $\mathcal{L}_{r[0]}$ induce metrics in the subspaces V and H which we denote $\langle \cdot, \cdot \rangle_{L_{n-r}}$ and $\langle \cdot, \cdot \rangle_{\mathcal{L}_{r[0]}}$ respectively.

Given an invariant metric on \mathcal{L}_r it is clear that its restriction to $T_{L_r^0} \mathcal{L}_r$ is invariant under the action of the isotropy group of L_r^0 . Besides, in order to know the invariant metric on the whole space \mathcal{L}_r it is enough to know this restriction.

Proposition 2.1.3. *Up to scalar factors, the tangent space $T_{L_r} \mathcal{L}_r$ admits one only semi-riemannian metric invariant under the isotropy group of L_r . This metric is*

$$\langle \cdot, \cdot \rangle_r = \langle \cdot, \cdot \rangle_{\mathcal{L}_{r[0]}} - \langle \cdot, \cdot \rangle_{L_{n-r}}. \quad (2.2)$$

Proof. Suppose a metric which is invariant under the action of the isotropy group. Since $G(n-r, n)$ admits one only (up to scalars) metric invariant under rotations, the restriction to H must be a multiple of $\langle \cdot, \cdot \rangle_{\mathcal{L}_r[0]}$. Since L_r admits one only metric invariant under its isotropy group, the restriction to V must be $\langle \cdot, \cdot \rangle_{L_r}$ or a scalar multiple.

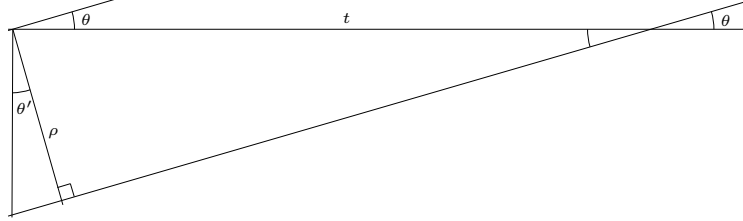

Figure 2.3: Curves x and $h \circ x$

Next we prove that v_0^j and v_i^j must be orthogonal and with opposite signature for $1 \leq i \leq r < j$. Let γ be the unit geodesic of L_r starting at e_0 with tangent vector e_i . Take a point $p = \gamma(t)$ and the parallel transport g_1, \dots, g_n of the chosen frame along γ up to p . Let h be the motion given by the obtained frame in p . The vector v_i^j correspond to the tangent vector of the curve $x(\theta) \subset \mathcal{L}_r$ obtained when turning L_r around p and $\langle e_i, e_j \rangle^\perp$, orthogonal complement of the space generated by e_i and e_j , with angle speed 1. The curve $h(x(\theta))$ moves L_r around p keeping it orthogonal to $\langle g_i, g_j \rangle$. If ρ is the distance from $h(x(\theta))$ to e_0 , and if θ' is the angle between $h(x(\theta))$ and γ (figure 2.3), then using the hyperbolic trigonometry formulas (1.2) we get

$$\sinh \rho = \sinh t \sin \theta \quad \text{and} \quad \cosh \rho \sin \theta' = \cosh t \sin \theta$$

where t is still the distance from e_0 to p . Then $dhv_i^j = \cosh t v_i^j + \sinh t v_0^j$. Finally if the metric is invariant, then for every t we must have

$$\langle v_i^j, v_i^j \rangle = \langle dhv_i^j, dhv_i^j \rangle = \cosh^2 t \langle v_i^j, v_i^j \rangle + 2 \cosh t \sinh t \langle v_0^j, v_i^j \rangle + \sinh^2 t \langle v_0^j, v_0^j \rangle.$$

Thus

$$\langle v_i^j, v_i^j \rangle = -\langle v_0^j, v_0^j \rangle \quad \text{and} \quad \langle v_0^j, v_i^j \rangle = 0.$$

□

Remark. The same arguments in \mathbb{R}^n lead to the following equation

$$\langle v_i^j, v_i^j \rangle = \langle v_i^j, v_i^j \rangle + 2t \langle v_0^j, v_i^j \rangle + t^2 \langle v_0^j, v_0^j \rangle \quad \forall t$$

which implies that v_0^j is a vector with null modulus. Therefore the only symmetric bilinear form in the space of r -planes of \mathbb{R}^n is degenerate.

A good introduction to the geometry of semi-riemannian manifolds, which we will cite often, is the book [O'N83]. For instance, there one can find formulas that allow to compute the sectional curvatures of \mathcal{L}_r with the preceding metrics.

Proposition 2.1.4. *Let G be a Lie group with a bi-invariant metric and G/H a homogeneous space with a metric such that $\pi : G \rightarrow G/H$ is a semi-riemannian submersion. Then, for every pair $X, Y \in \mathfrak{g}$, the sectional curvature of the plane defined by its projections is*

$$K(d\pi X, d\pi Y) = \frac{\frac{1}{4}\langle [X, Y]_m, [X, Y]_m \rangle + \langle [X, Y]_h, [X, Y]_h \rangle}{\langle X, X \rangle \langle Y, Y \rangle - \langle X, Y \rangle^2}$$

where Z_m and Z_h denote the normal and tangent parts to H of $Z \in \mathfrak{g}$.

Proof. Straight forward consequence of propositions 11.9 and 11.26 in [O’N83]. \square

Using this formula and lemma 1.1.2 one gets the sectional curvatures of \mathcal{L}_r ,

$$K(d\pi v_i^j, d\pi v_i^{j'}) = \langle v_j^{j'}, v_j^{j'} \rangle = 1 \quad \text{for } 0 \leq i \leq r < j < j'$$

$$K(d\pi v_i^j, d\pi v_{i'}^{j'}) = \langle v_i^{i'}, v_i^{i'} \rangle = 1 \quad \text{for } 0 \leq i < i' \leq r < j$$

$$K(d\pi v_i^j, d\pi v_{i'}^{j'}) = 0 \quad \text{for } 0 \leq i, i' \leq r < j, j' \quad i \neq i' \quad j \neq j'.$$

We are mostly interested in the codimension 1 case.

Corollary 2.1.5. *The space of hyperplanes in \mathbb{H}^n has constant sectional curvature equal to 1.*

Invariant measures

Locally, a semi-riemannian metric defines a volume element; that is, a top order differential form taking the values ± 1 on orthonormal basis (cf. [O’N83, p. 195]). In the case where the manifold is orientable this volume element can be made to be global. Otherwise, only the absolute value of this volume element is globally defined. Recall that the absolute value of a top order form is called a *density*, and defines a measure. From now on, unless otherwise stated, when we talk about measures we will be referring to densities. Moreover, the equalities between differential forms should be understood up to the sign. This is because we are only interested in the measures (densities) defined by these forms.

The volume element of the isometry group G , called *kinematic measure* in hyperbolic space, allows us to measure sets of motions \mathbb{H}^n . This is equivalent to measure sets of positions of geometric objects. The kinematic measure is bi-invariant and is defined by

$$dK = \bigwedge_{0 \leq i < j \leq n} \omega_i^j.$$

About the manifolds \mathcal{L}_r , its invariant measure dL_r (cf. [San76]) is given by

$$\pi_r^* dL_r = \bigwedge \omega_0^h \bigwedge \omega_i^j \quad 1 \leq i \leq r < j, h \leq n. \quad (2.3)$$

From now on, as usual, we will abuse the notation making $dL_r = \pi_r^* dL_r$. In the same way we will identify $\langle \cdot, \cdot \rangle_r = \pi_r^* \langle \cdot, \cdot \rangle_r$.

Thinking of \mathcal{L}_r in terms of the tautological bundle we can write dL_r in a different way.

Proposition 2.1.6 ([San76]). *The bi-invariant measure of \mathcal{L}_r is*

$$dL_r = \cosh^r \rho dx_{n-r} \wedge dL_{(n-r)[0]} \quad (2.4)$$

where dx_{n-r} is the volume element inside the orthogonal $(n-r)$ -plane by the origin, and $dL_{(n-r)[0]}$ is the volume element on the grassmannian of $(n-r)$ -planes by the origin.

Remark. Both in \mathbb{S}^n and in \mathbb{R}^n there are analogous measures of motions and planes (cf. [San76]).

Now we briefly describe a property of such measures that we will use after. Consider the *flag space* made of the couples of planes $L_r \subset L_{r+s}$. This is a homogeneous space of G and is at the same time a double fibred space over \mathcal{L}_r and \mathcal{L}_{r+s} . The fibre of an $(r+s)$ -plane are the r -planes it contains, and is identified with the space of r -planes in \mathbb{H}^{r+s} . The measure dL_r determines a measure in this fibre which we denote $dL_{[r+s]r}$. On the other hand, the fibre of an r -plane L_r are the $(r+s)$ -planes containing it and, it is diffeomorphical to $G(s, n-r)$. We denote by $dL_{(r+s)[r]}$ the natural measure in this fibre. It is deduced from (2.3) that

$$dL_{(r+s)[r]} dL_r = dL_{[r+s]r} dL_{r+s}. \quad (2.5)$$

This equality holds also in the analogous flag spaces of \mathbb{R}^n and \mathbb{S}^n .

2.2 Kinematic formulas

Classically, integral geometry is concerned on measuring sets of positions of geometrical objects. This is made with respect to the invariant measure we have just described. The result is a quite wide variety of the so-called *kinematic formulas*. Next we present a selection which holds in any constant curvature simply connected space.

The Cauchy-Crofton formula is the oldest and most known formula in integral geometry. It allows to compute the volume of a hypersurface by means of the integral of the number of its intersection points with a moving line.

Proposition 2.2.1. [San76] *Let S be a hypersurface of \mathbb{S}^n , \mathbb{R}^n or \mathbb{H}^n .*

$$\int_{\mathcal{L}_1} \#(L_1 \cap S) dL_1 = \frac{O_n}{O_1} M_0(S). \quad (2.6)$$

Recall that O_i is the volume of the unit sphere \mathbb{S}^i . It is worthy to mention the following fact about these volumes because we will use it often

$$\frac{O_n}{O_1} = \frac{O_{n-2}}{n-1}. \quad (2.7)$$

We give the proof of the Cauchy-Crofton formula in order to have an example of how the moving frames are used.

Proof. Consider the following bundle over S

$$E(S) = \{(p, L_1) \mid p \in L_1 \cap S\}.$$

Through the projection $E(S) \rightarrow \mathcal{L}_1$ we can lift the measure dL_1 to $E(S)$. This way, by the area formula (cf. [Fed69, 3.2.3])

$$\int_{\mathcal{L}_1} \#(L_1 \cap S) dL_1 = \int_{E(S)} dL_1.$$

Consider the adapted references

$$G(S) = \{g \in G \mid g_0 \in S \quad g_2, \dots, g_{n-1} \in T_{g_0}S\}.$$

There is a projection $G(S) \rightarrow E(S)$ which maps g to (g_0, L) where L is the geodesic line passing by g_0 with tangent vector g_1 . For every frame $g \in G(S)$ we take another $\bar{g} \in G(S)$ in such a way that

$$\bar{g}_0 = g_0, \quad \bar{g}_2 = g_2, \dots, \bar{g}_{n-1} = g_{n-1}, \quad \bar{g}_1 \in T_{g_0}S$$

Take the differential forms ω_i^j and $\bar{\omega}_i^j$ corresponding to g and \bar{g} respectively. Now,

$$g_n = \langle \bar{g}_1, g_n \rangle g_1 + \langle \bar{g}_n, g_n \rangle g_n$$

and since v_0^n is horizontal with respect to π , for all $v \in T_g G(S)$,

$$\omega_0^n(v) = -\langle v_0^n, v \rangle = -\langle d\pi v_0^n, d\pi v \rangle = -\langle g_n, d\pi v \rangle = \langle \bar{g}_1, g_n \rangle \bar{\omega}_0^1(v) + \langle \bar{g}_n, g_n \rangle \bar{\omega}_0^n(v)$$

and we have $\omega_0^n = \langle \bar{g}_1, g_n \rangle \bar{\omega}_0^1 + \langle \bar{g}_n, g_n \rangle \bar{\omega}_0^n$. But $\bar{\omega}_0^n$ vanishes on $G(S)$

$$\forall v \in T_g G(S) \quad \bar{\omega}_0^n(v) = -\langle v, v_0^n \rangle = -\langle d\pi v, d\pi v_0^n \rangle = 0$$

since $g_n = d\pi v_0^n$ is orthogonal to S . Thus

$$dL_1 = \bigwedge_{i=2}^n \omega_0^i \wedge \bigwedge_{i=2}^n \omega_1^i = \langle \bar{g}_1, g_n \rangle \bigwedge_{i=1}^{n-1} \bar{\omega}_0^i \wedge \bigwedge_{i=2}^n \omega_1^i = \sin \alpha dx du$$

where α is the angle of L_1 with S , dx is the volume element of S at the intersection point and du measures the direction of $T_x L_1$. Integrating $\sin \alpha du$ over $\mathbb{R}P^{n-1}$ we get the constant O_n/O_1 . \square

Thinking of $\#$ as the 0-dimensional volume, the Cauchy-Crofton formula generalizes in the following way.

Theorem 2.2.2. [San76, p. 245] *For a compact m -dimensional submanifold S immersed in S^n , \mathbb{R}^n or \mathbb{H}^n , the integral of the volume $\text{vol}_{r+m-n}(L_r \cap S)$ of intersections with r -planes is*

$$\int_{\mathcal{L}_r} \text{vol}_{r+m-n}(L_r \cap S) dL_r = \frac{O_n \cdots O_{n-r} O_{r+m-n}}{O_r \cdots O_0 O_m} \text{vol}_m(S). \quad (2.8)$$

Substituting the r -planes by arbitrary compact submanifolds and taking the measure dK instead of dL_r one gets the so-called Poincaré formula.

Theorem 2.2.3. [San76, p. 259] *Let R and S be two compact submanifolds of \mathbb{S}^n , \mathbb{R}^n or \mathbb{H}^n with dimensions r and m respectively, then*

$$\int_G \text{vol}_{r+m-n}(gR \cap S) dK = \frac{O_n \cdots O_1 O_{r+m-n}}{O_r O_m} \text{vol}_r(R) \text{vol}_m(S).$$

It is also remarkable the so-called *reproductive property* of the mean curvature integrals.

Proposition 2.2.4. [San76, p. 248] *For a hypersurface S in \mathbb{H}^n , \mathbb{R}^n or \mathbb{S}^n oriented by a unit normal \mathbf{n}*

$$\int_{\mathcal{L}_r} M_i^{(r)}(S \cap L_r) dL_r = \frac{O_{n-2} \cdots O_{n-r} O_{n-i}}{O_{r-2} \cdots O_0 O_{r-i}} M_i(\partial Q) \quad i < r$$

where $M_i^{(r)}$ denotes the i -th curvature integral considered inside an r -plane with respect to the unit normal \mathbf{n}' such that $\langle \mathbf{n}, \mathbf{n}' \rangle > 0$.

In euclidean space, for a domain $Q \subset \mathbb{R}^n$ with C^2 boundary, there is another generalization of the Cauchy-Crofton formula (cf. [San76, p. 248]).

$$M_{r-1}(\partial Q) = \frac{(n-r) \cdot O_{r-1} \cdots O_0}{O_{n-2} \cdots O_{n-r-1}} \int_{\mathcal{L}_r} \chi(L_r \cap Q) dL_r \quad (2.9)$$

where \mathcal{L}_r denotes the space of affine r -planes of \mathbb{R}^n and dL_r is the invariant measure on this space. When Q is convex, (2.9) can be thought of as a reformulation of the Cauchy equation (1.14). We see then that the Quermassintegrale of a convex domain coincide, up to constants, with the measure of planes intersecting it. Thus it is natural to generalize the Quermassintegrale to not necessarily convex domains $Q \subset \mathbb{R}^n$ in the following way (as it is also done in [Had57, p. 240])

$$W_r(Q) = \frac{(n-r) \cdot O_{r-1} \cdots O_0}{n \cdot O_{n-2} \cdots O_{n-r-1}} \int_{\mathcal{L}_r} \chi(L_r \cap Q) dL_r.$$

When ∂Q is smooth the Cauchy equation (2.2.5) will remain valid.

This definition of Quermassintegrale makes full sense for domains of \mathbb{H}^n and \mathbb{S}^n (recall the remarks at the end of section 1.2). Besides, it defines metric invariants. Thus we adopt the following

Definition 2.2.1. Let Q be a domain in \mathbb{H}^n (or \mathbb{R}^n or \mathbb{S}^n). For $r = 1, \dots, n-1$ we define

$$W_r(Q) = \frac{(n-r) \cdot O_{r-1} \cdots O_0}{n \cdot O_{n-2} \cdots O_{n-r-1}} \int_{\mathcal{L}_r} \chi(L_r \cap Q) dL_r.$$

Besides we define

$$W_0(Q) = V(Q) \quad \text{and} \quad W_n(Q) = \frac{O_{n-1}}{n} \chi(Q)$$

Even if it is not so simple, there is a generalization of the Cauchy equation (1.14) in simply connected spaces of constant curvature.

Proposition 2.2.5. *[San76] If Q is a domain in the n -dimensional, simply connected manifold of constant curvature k , and its boundary ∂Q is compact and of class C^2 , then for $r = 2l < n$*

$$W_r(Q) = \frac{2(n-r)}{nO_r O_{n-r-1}} \left[k^l O_{n-1} \text{vol}(Q) + \sum_{i=1}^l \binom{r-1}{2i-1} \frac{O_r O_{r-1} O_{n-2i+1}}{O_{2i-1} O_{r-2i} O_{r-2i+1}} k^{l-i} M_{2i-1}(\partial Q) \right] \quad (2.10)$$

and for $r = 2l + 1 < n$

$$W_r(Q) = \frac{2(n-r)}{nO_{n-r-1}} \sum_{i=0}^l \binom{r-1}{2i} \frac{O_{r-1} O_{n-2i}}{O_{2i} O_{r-2i-1} O_{r-2i}} k^{l-i} M_{2i}(\partial Q). \quad (2.11)$$

In chapter 3 we give a new proof of this fact that, in addition, gives some equivalent but much more simple formulas.

To finish the selection, we present Blaschke's fundamental kinematic formula in spaces of constant curvature k . It is analogous to the preceding when one takes compact domains instead of planes.

Theorem 2.2.6. *[San76] Let Q_0 and Q_1 be compact domains in a simply connected space of constant curvature k . Assume its boundaries to be of class C^2 . Then for even n*

$$\begin{aligned} \int_G \chi(Q_0 \cap gQ_1) dK = & -2(-1)^{n/2} \frac{O_{n-1} \cdots O_1}{O_n} V(Q_0)V(Q_1) + \\ & + O_{n-1} \cdots O_1 (V(Q_1)\chi(Q_0) + V(Q_0)\chi(Q_1)) + \\ & + O_{n-2} \cdots O_1 \frac{1}{n} \sum_{h=0}^{n-2} \binom{n}{h+1} M_h(\partial Q_0) M_{n-2-h}(\partial Q_1) + \\ & + O_{n-2} \cdots O_1 \sum_{i=0}^{n/2-2} k^{(n/2-i-1)} \binom{n-1}{2i+1} \frac{n-2i-2}{O_{n-2i-3}} \frac{2}{O_{n-2i-2}} \\ & \cdot \left[\sum_{h=n-2i-2}^{n-2} \frac{\binom{2i+1}{n-h-1} O_{2n-h-2i-2}}{(h+1)O_{n-h}} \frac{O_h}{O_{2i+h-n+2}} M_{n-2-h}(\partial Q_0) M_{h+2i+2-n}(\partial Q_1) \right], \end{aligned}$$

and for odd n

$$\begin{aligned} \int_G \chi(Q_0 \cap gQ_1) dK &= O_{n-1} \cdots O_1 (V(Q_1)\chi(Q_0) + V(Q_0)\chi(Q_1)) + \\ &+ O_{n-2} \cdots O_1 \frac{1}{n} \sum_{h=0}^{n-2} \binom{n}{h+1} M_h(\partial Q_0) M_{n-2-h}(\partial Q_1) + \\ &+ O_{n-2} \cdots O_1 \sum_{i=0}^{(n-3)/2} k^{(n-2i-1)/2} \binom{n-1}{2i} \frac{n-2i-1}{O_{n-2i-1}} \frac{2}{O_{n-2i-2}} \\ &\cdot \left[\sum_{h=n-2i-1}^{n-2} \frac{\binom{2i}{n-h-1} O_{2n-h-2i-1}}{(h+1)O_{n-h}} \frac{O_h}{O_{2i+h-n+1}} M_{n-2-h}(\partial Q_0) M_{h+2i+1-n}(\partial Q_1) \right]. \end{aligned}$$

This formula has a rather complicated aspect but it is worthy to say that it is extremely general. Indeed, even if it is stated for domains, it is also useful for pairs of compact submanifolds. It is enough to take the solid tube of each submanifold and both radii go to 0.

2.3 The de Sitter sphere

A very particular case among the spaces of hyperplanes in hyperbolic space is that of the space of hyperplanes. In this section we study it in detail.

Recall that according to corollary 2.1.5, \mathcal{L}_{n-1} has constant sectional curvature 1. For Lorentz manifolds one also has a Cartan classification theorem.

Theorem 2.3.1. [O'N83, 8.23 8.26] *Given $k \in \mathbb{R}$, there is a Lorentz manifold, unique up to isometry, simply connected and with constant sectional curvature k .*

The space \mathcal{L}_{n-1} is not simply connected, so that we will consider the space of oriented hyperplanes which is a double cover of \mathcal{L}_{n-1} , diffeomorphical to a cylinder and thus simply connected for $n > 2$.

Definition 2.3.1. The space of oriented hyperplanes of \mathbb{H}^n is called the n -dimensional *de Sitter sphere* and is denoted by Λ^n .

This way, for $n > 2$, the de Sitter sphere is the only simply connected Lorentz manifold with constant sectional curvature 1. For $n = 2$, the simply connected Lorentz surface of constant curvature 1 is the universal cover of Λ^2 .

Remark. In the Minkowski space, besides of the hyperboloid model of \mathbb{H}^n one also has a good model of the de Sitter sphere Λ^n . Indeed, an oriented hyperplane in the hyperboloid is given by an oriented linear hyperplane of \mathbb{R}^{n+1} containing some time-like vector. Such a hyperplane is uniquely determined by a normal unit vector given by the orientation which will be space-like. Thus, in this model

$$\Lambda^n = \{v \in \mathbb{R}^{n+1} \mid L(v, v) = 1\}.$$

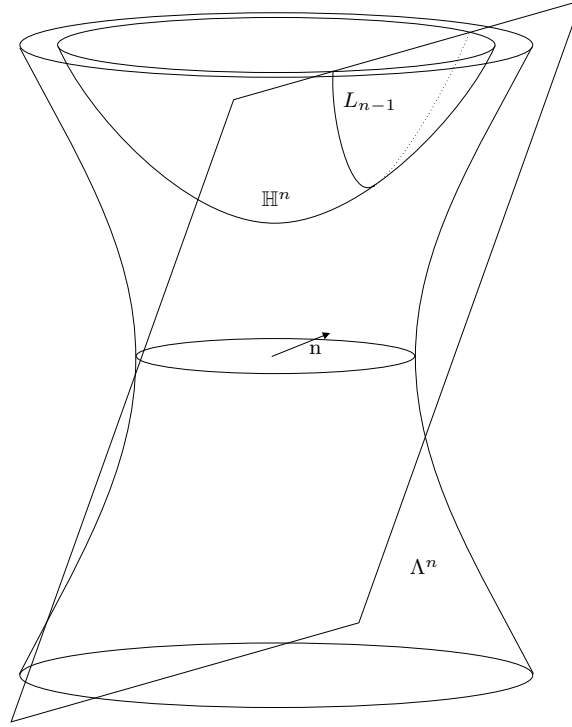

Figure 2.4: Hyperbolic space and the de Sitter sphere in Minkowski space.

Moreover, the semi-riemannian structure is the one induced by the Minkowski space. Even though we will keep on our abstract viewpoint, this can be a good way to visualize the de Sitter sphere. Concerning the projective model, we can say that via polarity \mathcal{L}_{n-1} is identified to the exterior points of the infinity conic.

Next we show that the orthonormal frame bundle of Λ^n is identified to that of \mathbb{H}^n . This will show the duality relation between \mathbb{H}^n and Λ^n . For convenience we denote by $(h_0, \dots, h_{n-1}; h_n)$ the orthonormal frames of Λ^n where $h_n \in \Lambda^n$ is the point and h_0, \dots, h_{n-1} is an orthonormal basis in h_n . Set then

$$\mathcal{F}(\Lambda^n) = \{(h_0, \dots, h_{n-1}; h_n) \mid h_n \in \Lambda^n \quad h_0, \dots, h_{n-1} \in T_{h_n} \Lambda^n \quad \langle h_i, h_j \rangle = \epsilon(i) \delta_{ij}\}$$

where $\epsilon(0) = -1$ and $\epsilon(i) = 1$ for $1 \leq i \leq n-1$. Thus, $\tilde{\pi} : \mathcal{F}(\Lambda^n) \rightarrow \Lambda^n$ is a principal bundle with structural group $O(n-1, 1)$. One can think of the frames h as linear isometries from the Minkowski space \mathbb{R}^n to $T_{\tilde{\pi}(h)} \Lambda^n$. Let $\tilde{\theta} = h^{-1} d\tilde{\pi}$ be the dual (or canonic) form of the bundle $\tilde{\pi}$. Consider the i -th component of θ

$$\tilde{\omega}_i^n = \tilde{\theta}_i \quad i = 0, \dots, n-1$$

where we think of the coordinates of \mathbb{R}^n to be numbered from 0 to $n-1$. Denote $\tilde{\sigma}$ the infinitesimal action of the bundle. Take the collection of matrices $\{Y_i^j\} \subset \mathfrak{o}(n-1, n)$

with zeros in all the components except of $(Y_i^j)_i^j = 1$ and $(Y_i^j)_j^i = -\epsilon(i)\epsilon(j)$

$$Y_0^i = \begin{pmatrix} 0 & \dots & 1 & \dots & 0 \\ \vdots & & \vdots & & \vdots \\ 1 & \dots & 0 & \dots & 0 \\ \vdots & & \vdots & & \vdots \\ 0 & \dots & 0 & \dots & 0 \end{pmatrix} \quad Y_i^j = \begin{pmatrix} 0 & \dots & 0 & \dots & 0 & \dots & 0 \\ \vdots & & \vdots & & \vdots & & \vdots \\ 0 & \dots & 0 & \dots & 1 & \dots & 0 \\ \vdots & & \vdots & & \vdots & & \vdots \\ 0 & \dots & -1 & \dots & 0 & \dots & 0 \\ \vdots & & \vdots & & \vdots & & \vdots \\ 0 & \dots & 0 & \dots & 0 & \dots & 0 \end{pmatrix}.$$

We construct the following vector fields for $0 \leq i, j \leq n-1$ and $i \neq j$:

$$\tilde{v}_i^j = \tilde{\sigma}(Y_i^j).$$

Let $\tilde{\omega}$ be the connection form with values in $\mathfrak{o}(n-1, 1)$ corresponding to $\tilde{\nabla}$, the Levi-Civita connection of Λ^n . Let us number from 0 to $n-1$ the rows and columns of these matrices and denote by $\tilde{\omega}_i^j$ the position i, j of $\tilde{\omega}$. We have

$$\tilde{\omega}_i^j + \epsilon(i)\epsilon(j)\tilde{\omega}_j^i = 0. \quad (2.12)$$

Each $x \in \mathbb{R}^n$ has an associated the basic field $\tilde{B}(x)$, which is horizontal and defined by $d\tilde{\pi}_h \tilde{B}(x) = h(x)$. We can construct, for the canonical frame e_0, \dots, e_{n-1} of \mathbb{R}^n ,

$$\tilde{v}_i^n = -\tilde{v}_n^i = \tilde{B}(e_i).$$

On the other hand, since Λ^n has constant curvature, after choosing some frame its isometry group \tilde{G} is identified to $\mathcal{F}(\Lambda^n)$ (cf.[O'N83, 8.17]). If e is the chosen frame in \mathbb{H}^n , we take the following frame in Λ^n

$$(h_0, \dots, h_{n-1}; h_n) = ((d\pi_{n-1}v_0^n)_e, \dots, (d\pi_{n-2}v_{n-1}^n)_e; \pi_{n-1}(e))$$

As in \mathbb{H}^n , the structure equations of the principal bundle determine the Lie bracket.

$$\begin{aligned} [X, Y] &= \tilde{\sigma}([\tilde{\omega}(X), \tilde{\omega}(Y)]) + \tilde{\sigma}(\tilde{\theta}(X) \cdot \tilde{\theta}(Y)^t - \tilde{\theta}(Y) \cdot \tilde{\theta}(X)^t) + \\ &+ \tilde{B}(\tilde{\omega}(X) \cdot \tilde{\theta}(Y) - \tilde{\omega}(Y) \cdot \tilde{\theta}(X)) \end{aligned}$$

In particular

$$\begin{aligned} [\tilde{v}_i^j, \tilde{v}_j^s] &= \tilde{v}_i^s \quad \text{si } i \neq s \neq j \\ [\tilde{v}_i^j, \tilde{v}_r^s] &= 0 \quad \text{si } i < j < r < s. \end{aligned}$$

But recall that G acts transitively and effectively on Λ^n by isometries. Therefore, we have a map

$$\begin{aligned} \Phi : G &\longrightarrow \tilde{G} = \mathcal{F}(\Lambda^n) \\ g &\longmapsto (dgh_0, \dots, dgh_{n-1}; g(h_n)) \end{aligned}$$

which is an injective morphism of Lie groups. Since the dimensions of G and \tilde{G} coincide, we can think that they have the same connected component of the neuter element. But it is easily seen that they both have two connected components. Therefore Φ is a Lie group isomorphism. In particular,

$$\Phi^* K_{\tilde{\mathfrak{g}}} = K_{\mathfrak{g}} \quad (2.13)$$

being $K_{\tilde{\mathfrak{g}}}$, the Killing form of \tilde{G} .

We are interested in computing the pull-back of the differential forms $\tilde{\omega}_i^j$. Let us start noting that for $i = 0, \dots, n-1$ and v tangent to G ,

$$\begin{aligned} \Phi^* \tilde{\omega}_i^n(v) &= \tilde{\omega}_i^n(d\Phi v) = (h^{-1})_i d\tilde{\pi} d\Phi v = (h^{-1})_i d\pi_{n-1} v = \\ &= \epsilon(i) \langle d\pi_{n-1} v, h_i \rangle = \epsilon(i) \langle d\pi_{n-1} v, d\pi_{n-1} v_i^n \rangle = -\epsilon(i) \langle v, v_i^n \rangle = \omega_i^n(v) \end{aligned} \quad (2.14)$$

since the metric of Λ^n is lifted to that of $\langle \tilde{v}_0^n, \dots, \tilde{v}_{n-1}^n \rangle$. Since Λ^n is a symmetric space, the vertical and horizontal parts are orthogonal with respect to $K_{\tilde{\mathfrak{g}}}$. By (2.13) we see that $d\Phi v_i^n$ is orthogonal to the fibers of $\tilde{\pi}$ and thus must be horizontal. Then it is a linear combination of $\tilde{v}_0^n, \dots, \tilde{v}_{n-1}^n$ and for (2.14), we have $d\Phi(v_i^n) = \tilde{v}_i^n$. For the rest of v_i^j , one can argue as follows

$$d\Phi(v_i^j) = -\epsilon(i)\epsilon(j) d\Phi([v_i^n, v_j^n]) = -\epsilon(i)\epsilon(j) [d\Phi v_i^n, d\Phi v_j^n] = -\epsilon(i)\epsilon(j) [\tilde{v}_i^n, \tilde{v}_j^n] = \tilde{v}_i^j.$$

Therefore

$$d\Phi(v_i^j) = \tilde{v}_i^j \quad \Rightarrow \quad \Phi^*(\tilde{\omega}_i^j) = \omega_i^j \quad 0 \leq i, j \leq n.$$

To make the notation lighter, from now on we completely identify G and \tilde{G} . In particular, we will write ω_i^j and v_i^j instead of $\tilde{\omega}_i^j$ and \tilde{v}_i^j .

Geometrically $h_0 = d\tilde{\pi}v_0^n$ is interpreted as the infinitesimal element of the parallel transport of a hyperplane along the geodesic orthogonal in the point g_0 . About $h_i = d\tilde{\pi}v_i^n$ for $i > 0$, it can be thought of as the rotation element around $L_{n-2} = \exp_{g_0}(\langle g_1, \dots, \hat{g}_i, \dots, g_{n-1} \rangle)$. Thus, the time-like directions of $T_{L_{n-1}}\Lambda^n$ are identified to the points of L_{n-1} itself and the space-like directions are identified to the $(n-2)$ -planes it contains.

2.3.1 Spaces of planes in the de Sitter sphere

Given a non-oriented $(n-r-1)$ -plane $L_{n-r-1} \in \mathcal{L}_{n-r-1}$, consider the submanifold of Λ^n consisting of the oriented hyperplanes containing it

$$L_r^s = \{L_{n-1} \in \Lambda^n | L_{n-r-1} \subset L_{n-1}\}.$$

Clearly L_r^s is diffeomorphic to the sphere \mathbb{S}^r . Now consider the isometries leaving invariant L_{n-r-1} and all the hyperplanes containing it. Such isometries act on Λ^n and for some of them L_r^s is the locus of fixed points. We deduce that L_r^s is a totally geodesic submanifold of Λ^n . Besides, the tangent space to L_r^s is space-like. Such a submanifold will

be called a *space-like r -plane* of Λ^n . In particular, the curves L_1^s , which are hyperplane bundles containing some L_{n-2} , are *space-like geodesic lines*.

For some r -plane L_r of \mathbb{H}^n consider the hyperplanes intersecting it orthogonally

$$L_r^t = \{L_{n-1} \in \Lambda^n \mid L_{n-1} \perp L_r\}.$$

It is clear that L_r^t is diffeomorphical to Λ^r . Again we have a totally geodesic submanifold of Λ^n . For $r = 1$ it is a bundle of hyperplanes orthogonal to some geodesic. This bundle is itself a geodesic line in the de Sitter sphere and, having time-like tangent vectors, it is called a *time-like geodesic line* of Λ^n . Note that there is a canonical way to give an orientation to the time-like geodesic lines of Λ^n . Indeed, if L_1^t is the bundle of hyperplanes orthogonal to some geodesic line L_1 of \mathbb{H}^n , we orient L_1 in such a way that its tangent vectors are the normal vectors defined by the orientation of the hyperplanes, and this determines an orientation of L_1^t . Since for $r > 1$, the planes L_r^t contain time-like lines, we say that L_r^t is a *time-like r -plane* of Λ^n .

Definition 2.3.2. Denote by \mathcal{L}_r^s and \mathcal{L}_r^t the spaces of space-like and time-like r -planes of Λ^n respectively.

The space of space-like r -planes is identified to \mathcal{L}_{n-r-1} and is thus a smooth manifold with a semi-riemannian metric and a measure dL_r^s which are invariant under the action of G

$$dL_r^s = \bigwedge \omega_0^h \bigwedge \omega_i^j \quad 1 \leq i \leq n-r-1 < j, h \leq n.$$

On the other hand, the space \mathcal{L}_r^t is identified to \mathcal{L}_r and its measure is $dL_r^t = dL_r$.

A short computation will show the difficulty of doing integral geometry in Λ^n . Let us try to repeat the proof of the Cauchy-Crofton formula (proposition 2.2.1). Suppose a space-like hypersurface $S \subset \Lambda^n$. Consider the spaces

$$E(S) = \{(p, L) \in S \times \mathcal{L}_1^s \mid p \in L \cap S\}$$

$$G(S) = \{h \in \mathcal{F}(\Lambda^n) \mid h_n \in S \quad h_1, \dots, h_{n-2} \in T_{h_n} S\}$$

and the projection $G(S) \rightarrow E(S)$ defined by $h \mapsto (h_n, L)$ where L is the time-like geodesic starting at h_n with tangent vector h_{n-1} . For every frame $h \in G(S)$ take some other frame $\bar{h} \in G(S)$ such that

$$\bar{h}_1 = h_1, \dots, \bar{h}_{n-2} = h_{n-2}, \quad \bar{h}_n = h_n, \quad \bar{h}_{n-1} \in T_{h_n} S$$

Take the differential forms ω_i^j and $\bar{\omega}_i^j$ corresponding to h and \bar{h} . Then,

$$\bar{h}_0 = \langle \bar{h}_0, h_{n-1} \rangle h_{n-1} + \langle \bar{h}_0, h_0 \rangle h_0 \quad \Rightarrow \quad \omega_0^n = \langle \bar{h}_0, h_{n-1} \rangle \bar{\omega}_{n-1}^n + \langle \bar{h}_0, h_0 \rangle \bar{\omega}_0^n$$

But it is clear that $\bar{\omega}_0^n = 0$ on $G(S)$. Thus,

$$dL_1^s = \bigwedge_{i=0}^{n-2} \omega_i^n \wedge \bigwedge_{i=0}^{n-2} \omega_i^{n-1} = \langle \bar{h}_{n-1}, h_0 \rangle \bigwedge_{i=1}^{n-1} \bar{\omega}_i^n \wedge \bigwedge_{i=0}^{n-2} \omega_i^{n-1} = \sinh \rho dx du$$

where dx is the volume element of S in the intersection point x , du is the measure of space-like unit directions in x and $\sinh \rho$ is the Lorentz product of L_1 and the normal vector to S . But the integral of $\sinh \rho du$ over all the space-like directions is divergent. Therefore, following the scheme of the proof of 2.2.1 we must stop before the last step. We have not proved any Cauchy-Crofton formula in Λ^n but instead we have proved the following proposition.

Proposition 2.3.2. *The measure of space-like lines intersecting some space-like hypersurface in Λ^n is infinite.*

It is analogous to see that the same happens with time-like lines or also with time-like hypersurfaces.

Note that the problem comes from the fact that the space of space-like lines passing by a point in Λ^n is not compact (and with infinite measure). It is clear here the importance of the fact that Λ^n is a Lorentz manifold and not a Riemann one. In fact, in any semi-riemannian manifold one can expect to have the same trouble in the way to kinematic formulas.

On the other hand, recalling that the space-like lines in Λ^n correspond to $(n - 2)$ -planes of \mathbb{H}^n , the previous proposition was to be expected. A family of hyperplanes in \mathbb{H}^n , no matter how ‘small’ it is, should contain an infinite measure set of $(n - 2)$ -planes.

We finish with an important remark. Suppose $p \in L \in \Lambda^n$ and consider the hyperplane $L_{n-1}^s \subset \Lambda^n$ consisting of the hyperplanes that, as L , contain p .

Proposition 2.3.3. *The tangent spaces $T_p L$ and $T_L L_{n-1}^s$ are canonically identified through and isometry Ψ .*

Proof. We define Ψ first on the unitary tangent bundle of L at p in the following way. For $v \in T_p L$ with length 1

$$\Psi(v) = \left. \frac{d}{dt} \right|_{t=0} \exp(\cos tv + \sin tn)$$

where n is the unit normal vector to L at p given by the orientation of L . We extend Ψ to $\Psi : T_p L \rightarrow T_L L_{n-1}^s$ linearly. To see that Ψ is an isometry it is enough to take a frame $g \in G$ such that $g_0 = p$ and $g_n = n$. Then for $i = 1, \dots, n - 1$ one sees that $\Psi(g_i) = d\tilde{\pi}_g(v_i^n)$. \square

2.3.2 The Gauss map

The de Sitter sphere is the natural target space of the Gauss map of a hypersurface in \mathbb{H}^n . This map was already studied in [Teu82].

Definition 2.3.3. Let $S \subset \mathbb{H}^n$ be an oriented hypersurface. The *Gauss map* of S is defined as

$$\begin{aligned} \gamma : S &\longrightarrow \Lambda^n \\ p &\longmapsto \exp_p(T_p S) \end{aligned}$$

When S is non oriented one can naturally define a Gauss map to \mathcal{L}_{n-1} or a map from the unit normal bundle $N(S)$ to Λ^n .

The following proposition allows, as in \mathbb{R}^n , to think of the differential of the Gauss map as an endomorphism of T_pS .

Proposition 2.3.4. [Teu82] *If $S \subset \mathbb{H}^n$ is a hypersurface in the hyperbolic space and $\gamma : S \rightarrow \Lambda^n$ is the corresponding Gauss map, then $d\gamma(T_pS)$ is isometrically identified through Ψ^{-1} to a subspace of T_pS .*

Therefore, when $d\gamma$ has maximum rank, $\gamma(S)$ is locally a space-like hypersurface of Λ^n .

Proof. Let $g : U \rightarrow G$ be a moving frame defined in a neighborhood of p inside S in such a way that $g_n \perp T_{g_0}S$. This way, $\gamma = \tilde{\pi} \circ g$ and for $i = 1, \dots, n-1$,

$$\langle d\gamma g_i, d\tilde{\pi} v_0^n \rangle = \langle d\tilde{\pi} dg(g_i), d\tilde{\pi} v_0^n \rangle = \langle dg(g_i), v_0^n \rangle = \langle d\pi dg(g_i), d\pi(v_0^n) \rangle = -\langle g_i, g_n \rangle = 0$$

since v_0^n is horizontal with respect to $\tilde{\pi}$ and π . Thus, if L is the tangent hyperplane to S at p and L_{n-1}^s is the hyperplane of Λ^n consisting of the hyperplanes containing p , then we have $d\gamma(T_pS) \subset (d\tilde{\pi} v_0^n)^\perp = T_L L_{n-1}^s$ which is identified to $T_pL = T_pS$ through Ψ^{-1} according to proposition 2.3.3. \square

As in the euclidean case, we have a Weingarten formula.

Proposition 2.3.5. *If \mathbb{I} denotes the second fundamental form of S corresponding to the unit normal \mathbf{n} , then for any pair of tangent vectors X, Y*

$$\langle d\gamma X, \Psi Y \rangle = -\mathbb{I}(X, Y).$$

Proof. Take some section $g : U \rightarrow G$ as before.

$$\begin{aligned} \langle d\gamma(g_i), \Psi g_j \rangle &= \langle d\gamma(g_i), d\tilde{\pi} v_j^n \rangle = \langle dg(g_i), v_j^n \rangle = \omega_j^n(dg(g_i)) = \\ &= -\omega_n^j(dg(g_i)) = \langle -\nabla_{g_i} g_j, g_n \rangle = -\mathbb{I}(g_i, g_j). \end{aligned}$$

\square

Therefore, the Gauss curvature of S is, up to the sign, the jacobian (infinitesimal volume deformation) of γ (cf.[Teu82])

$$K = \det \mathbb{I} = \pm \det d\gamma = \pm \text{jac} \gamma. \quad (2.15)$$

The Sard-Federer theorem [Fed69, 3.4.3] warrants that the set of critical values of γ has null $(n-1)$ -dimensional Hausdorff measure. Thus, the Gauss map image of S is a hypersurface almost everywhere. If $d\tilde{x}$ is the volume element of $\gamma(S)$ in a regular point, we have just seen that

$$M_{n-1}(S) = \int_S K dx = \int_{\gamma(S)} \text{sgn} K d\tilde{x}. \quad (2.16)$$

Remark. This point of view allows to define M_{n-1} for the boundary of a convex set in \mathbb{H}^n even if it is not smooth. For any convex Q , a hyperplane is said to support Q when it meets his closure \overline{Q} but leaves Q at some side. We define the total curvature of $M_{n-1}(\partial Q)$ as the $(n-1)$ -dimensional volume of the subset of Λ^n consisting of the hyperplanes supporting Q . By (2.16), if ∂Q is smooth then both definitions coincide. Besides, M_{n-1} is a continuous functional in the space of convex domains with respect to the Hausdorff topology. Indeed, a convex domain Q can be approximated (with respect to this topology) by a sequence Q_r of convex sets with smooth boundary. It is seen in [LS00] that $M_{n-1}(\partial Q_r)$ tends to $M_{n-1}(\partial Q)$, as has just been defined.

Curvature integrals in constant curvature spaces have been defined and studied for sets of *positive reach*; a much more general class than that of convex sets (cf. [Koh91]).

In contrast with the euclidean case, but similarly to the spherical case, one can define a Gauss map going in the opposite sense. We can not give a reference where this map is studied but it probably belongs to the *folklore*.

Definition 2.3.4. Given $S \subset \Lambda^n$ a space-like hypersurface in the de Sitter sphere, the Gauss map of S is defined as

$$\begin{aligned} \tilde{\gamma} : S &\longrightarrow \mathcal{L}_{n-1}^s \equiv \mathbb{H}^n \\ p &\longmapsto \exp_p(T_p S) \end{aligned}$$

where \exp_p is the exponential map of Λ^n in p .

Proposition 2.3.4 has the following analogue in Λ^n .

Proposition 2.3.6. *If $\tilde{\gamma}$ is the Gauss map associated to a hypersurface $S \subset \Lambda^n$, then*

$$\Psi d\tilde{\gamma}(T_p S) \subset T_p S.$$

Proof. Let $g : U \rightarrow G$ be a section defined in a neighborhood of p inside S such that the moving frame $h = \Phi(g) \in \mathcal{F}(\Lambda^n)$ fulfills $h_0 \perp T_{h_n} S$. Thus, $\tilde{\gamma} = \pi \circ g$ and for $i = 1, \dots, n-1$

$$\langle d\tilde{\gamma}(h_i), g_n \rangle = \langle d\pi dg(h_i), d\pi v_0^n \rangle = \langle dg(h_i), v_0^n \rangle = \langle d\tilde{\pi} dg(h_i), d\tilde{\pi} v_0^n \rangle = -\langle h_i, h_n \rangle = 0.$$

Therefore, $d\tilde{\gamma} \subset (g_n)^\perp$ is identified to $T_p S = h_0^\perp$ through Ψ . \square

Given a space-like hypersurface in Λ^n , take its (time-like) unit normal n according to the time orientation of Λ^n . If $\tilde{\nabla}$ is the connection in Λ^n , the fundamental form of S is defined as

$$\tilde{I}(X, Y) = \langle \tilde{\nabla}_X Y, n \rangle.$$

We again have a Weingarten formula

Proposition 2.3.7. *The second fundamental form \tilde{I} of a space-like hypersurface S in Λ^n is such that for every pair of tangent vectors X, Y ,*

$$\langle d\tilde{\gamma} X, \Psi^{-1} Y \rangle = -\tilde{I}(X, Y).$$

Proof. Take some section $g : U \rightarrow G$ as in the previous proof, and consider $h = \Phi \circ g$.

$$\langle d\tilde{\gamma}h_i, \Psi^{-1}h_j \rangle = \langle d\pi dg(h_i), g_j \rangle = -\langle dg(h_i), v_0^j \rangle = \omega_0^j(dg(h_i)) = -\langle \tilde{\nabla}_{h_i}h_j, h_0 \rangle.$$

□

We get again that the Gauss curvature measures the infinitesimal volume deformation through $\tilde{\gamma}$

$$\tilde{K} = \det \tilde{II} = \pm \det d\tilde{\gamma}.$$

Finally we have the following result that completes the idea of duality between hypersurfaces in \mathbb{H}^n and in Λ^n . Again we can not give a reference for it even though it is probably already known. Anyway it is trivially proved, and it will play an important role after.

Proposition 2.3.8. *If the hypersurface $S \subset \mathbb{H}^n$ is such that γ is an immersion, then the second fundamental forms of S and of $\gamma(S)$ are mutually inverse. More precisely, if II and \tilde{II} are the second fundamental forms of S and $\gamma(S)$ respectively, then its respective matrices A and \tilde{A} , associated to the orthonormal basis g_1, \dots, g_{n-1} and $\Psi g_1, \dots, \Psi g_{n-1}$, are inverse one of the other*

$$A \cdot \tilde{A} = \text{id}.$$

Note that γ is an immersion if and only if the Gauss curvature K of S does not vanish anywhere.

Proof. Denote by $\tilde{\gamma}$ the Gauss map associated to $\gamma(S) \subset \Lambda^n$. Note that \tilde{A} is also the matrix associated to $\Psi^*\tilde{II}$ in the basis g_1, \dots, g_{n-1} . Besides, by the preceding Weingarten formulas $-\Psi^{-1}d\gamma$ and $-\Psi d\tilde{\gamma}$ are the associated endomorphisms of II and \tilde{II} . Thus, for $X, Y \in T_p S$ we have

$$\begin{aligned} X^t \cdot A \tilde{A} \cdot Y &= (X^t A) \cdot \tilde{A} \cdot Y = \Psi^* \tilde{II}(AX, Y) = \Psi^* \tilde{II}(-\Psi^{-1}d\gamma X, Y) = \\ &= \tilde{II}(-d\gamma X, \Psi Y) = \langle d\tilde{\gamma}d\gamma X, Y \rangle = \langle X, Y \rangle \end{aligned}$$

since $\tilde{\gamma} \circ \gamma = \text{id}$.

□

Corollary 2.3.9. *If $\sigma_r(x)$ and $\tilde{\sigma}_r(\gamma(x))$ are the symmetric curvature functions of $S \subset \mathbb{H}^n$ and $\gamma(S) \subset \Lambda^n$, in the points x and $\gamma(x)$ respectively, then*

$$\sigma_r(x) = \sigma_{n-1}(x) \tilde{\sigma}_{n-r}(\gamma(x)).$$

Proof. Choose a basis where II diagonalizes and automatically \tilde{II} diagonalizes with inverse coefficients. Therefore,

$$\tilde{\sigma}_{n-r} \binom{n-1}{n-r} = f_{n-r}(1/k_1, \dots, 1/k_{n-1}) = \frac{f_r(k_1, \dots, k_{n-1})}{k_1 \cdots k_{n-1}} = \frac{\sigma_r}{\sigma_{n-1}} \binom{n-1}{r}$$

being f_i the elementary symmetric polynomial of degree i .

□

2.4 Contact measures.

Next we introduce some results of [Teu86] about the measure of tangent planes of a hypersurface in \mathbb{H}^n (o \mathbb{R}^n o \mathbb{S}^n). This results generalitze (2.15) for higher codimensional planes. After we will give analogous results for hypersurfaces in Λ^n .

Definition 2.4.1. If $S \subset \mathbb{H}^n$ (or \mathbb{R}^n or \mathbb{S}^n) is a smooth hypersurface, we call *contact r -planes* of S to those planes that are tangent to S at some point. Denote $\mathcal{L}_r(S)$ the subset of \mathcal{L}_r containing all such r -planes.

One can parametritze $\mathcal{L}_r(S)$ through a generalized Gauss map. Consider the following manifold of dimension $(r + 1)(n - r) - 1$

$$G_r(S) = \{(p, V_r) \mid p \in S \quad V_r \in G(r, T_p S)\}$$

where $G(r, T_p S)$ denotes the grassmannian of the r -dimensional linear subspaces of $T_p S$. The r -th generalized Gauss map is defined as r

$$\begin{aligned} \gamma_r : G_r(S) &\longrightarrow \mathcal{L}_r \\ (p, V_r) &\longmapsto \exp_p(V_r). \end{aligned}$$

it is clear that its image $\gamma_r(G_r(S))$ is $\mathcal{L}_r(S)$, which is a hypersurface of \mathcal{L}_r out of the set of critical values. By the Sard-Federer theorem [Fed69, 3.4.3], this set has null Hausdorff measure of dimension $(r + 1)(n - r) - 1$. Thus, $\mathcal{L}_r(S)$ is regular almost everywhere. In the regular points, we take the volume element of $\mathcal{L}_r(S)$ defined by the contraction of dL_r with some unit normal n .

In $G_r(S)$ we take the volume element $dG_r dp$, exterior product of the volume element of S with the natural volume element of $G(r, T_p S)$ for each p .

Theorem 2.4.1. [Teu86] *The pull-back of the contraction $\iota_n dL_r$ through γ_r in a point $(p, V_r) \in G_r(S)$ is, up to the sign*

$$\gamma_r^*(\iota_n dL_r) = |K_p(V_r)| dG_r dp$$

where $K_p(V_r)$ is the normal curvature of S in the direction of the subspace $V_r \subset T_p S$.

Corollay 2.4.2. [Teu86] *The (signed) measure of the contact r -planes of S is*

$$\int_{\mathcal{L}_r(S)} \text{sgn}(K_p(L_r)) dL_r = \text{vol } G(r, n - 1) \cdot M_r(S)$$

and for any integrable function f defined on S

$$\int_{\mathcal{L}_r(S)} f \cdot \text{sgn}(K_p(L_r)) dL_r = \text{vol } G(r, n - 1) \int_S f(x) \sigma_r(x) dx$$

For the de Sitter sphere the preceding results are easily generalized as we next do. The following are new results with some interest in its own but we mainly introduce them because they will be used after.

Let $S \subset \Lambda^n$ be some space-like hypersurface. Consider the grassmann fiber of S

$$G_r(S) = \{(x, V_r) \mid V_r \in G(r, T_x S)\}$$

and the map

$$\begin{aligned} \tilde{\gamma}_r : G_r(S) &\longrightarrow \mathcal{L}_r^s \\ (p, V_r) &\longmapsto \exp_p(V_r). \end{aligned} \quad (2.17)$$

The image of $\tilde{\gamma}_r$ are the contact r -planes of S and we denote it by $\mathcal{L}_r^s(S)$.

Proposition 2.4.3. *If S is a space-like hypersurface, its pull-back under $\tilde{\gamma}_r$ of the volume form of $\mathcal{L}_r^s(S)$ at a regular point $(p, V_r) \in G_r(S)$ is*

$$\tilde{\gamma}_r^*(\iota_n dL_r^s) = |K_p(V_r)| dp dG(r, T_p S)$$

where n is a unit normal vector on $\mathcal{L}_r^s(S)$ and $K_p(V_r)$ is the normal curvature of S in the direction V_r .

Proof. Take some orthonormal frame (section) $h : U \rightarrow \mathcal{F}(\Lambda^n)$ in an open subset U of $\mathcal{L}_r^s(S)$ in such a way that for every $\tilde{\gamma}_r(p, V_r)$

$$h_n = p \in S \quad \langle h_{n-r}, \dots, h_{n-1} \rangle = V_r \quad \langle h_1, \dots, h_{n-1} \rangle = T_p S.$$

Then

$$dL_r^s = \bigwedge \omega_0^h \wedge \bigwedge \omega_i^j \quad 0 < i \leq n-r-1 < h, j \leq n$$

It is clear that n , the unit normal of $\mathcal{L}_r^s(S)$ is v_0^n . Then,

$$\iota_n dL_r^s = \bigwedge \omega_0^h \wedge \bigwedge \omega_i^j \quad 0 < i \leq n-r-1 < j \leq n \quad n-r \leq h \leq n-1$$

As a consequence of proposition 2.3.7, for every $v \in T_p S$,

$$\omega_0^i(dhv) = -\langle \Psi d\pi dh(v), h_i \rangle = \tilde{H}(v, h_i) = \tilde{H}\left(\sum_j \omega_j^n(dhv) h_j, h_i\right) = \sum_j \tilde{H}(h_i, h_j) \omega_j^n(dhv)$$

And thus,

$$\omega_0^{n-r} \wedge \dots \wedge \omega_0^{n-1} = K(V) \omega_{n-r}^n \wedge \dots \wedge \omega_{n-1}^n + \sum_{i=1}^{n-r-1} \omega_i^n \wedge \eta_i$$

for some η_i . Finally,

$$\iota_n dL_r^s = K(V) \bigwedge \omega_h^n \bigwedge \omega_i^j \quad 0 < i \leq n-r-1 < j \leq n-1 \quad 1 \leq h \leq n-1$$

□

Corollary 2.4.4. *The (signed) volume of $\mathcal{L}_r^s(S)$ is*

$$\int_{\mathcal{L}_r^s(S)} \operatorname{sgn}K(L_r) \iota_n dL_r^s = \operatorname{vol}(G(r, n-1)) \int_S \sigma_r(x) dx,$$

and more generally, for a function f in S ,

$$\int_{\mathcal{L}_r^s(S)} f \cdot \operatorname{sgn}K(L_r) \iota_n dL_r^s = \operatorname{vol}(G(r, n-1)) \int_S f \sigma_r(x) dx. \quad (2.18)$$

Proof. We finish by integrating the preceding result and using proposition (1.2.1) which holds in semi-riemannian ambient. Indeed, it is a general (algebraic) property of the symmetric bilinear forms. \square

2.5 Cauchy-Crofton formula in the de Sitter sphere.

Here we prove a formula for the integral of the number of intersection points of space-like lines with a space-like hypersurface in Λ^n . The formula relates directly this integral to the $(n-1)$ -dimensional volume of the hypersurface. This are reasons enough to call it Cauchy-Crofton formula in the de Sitter sphere. However, it must be prevented that at a first glance the formula does not look exactly as the usual Cauchy-Crofton formulas existing in constant curvature spaces or in homogeneous riemannian manifolds. We have already said that in these ambients, these formulas are in the style of

$$\int_{\mathcal{L}} \#(L \cap S) dL = c \cdot \operatorname{vol}(S) \quad (2.19)$$

where dL is a measure in \mathcal{L} , the space of space-like geodesics, S is a hypersurface and c is a constant. In the de Sitter sphere there is no such formula since for any small piece of hypersurface there is an infinite measure set of intersecting space-like lines, as seen in proposition 2.3.2. In general, the same problem does not allow to have formulas in the style of (2.19) on semi-riemannian manifolds.

A way to solve this trouble appears in [Teu82]. It consists of counting only the intersections occurring with an angle below some fixed value. This restricts the integration to the interior of some compact set of L_1^s . This way, the integral is finite and it is shown to be multiple of the volume of the hypersurface.

Here we propose an alternative approach which will lead to a different kind of formula but which will have into account all the intersection points. The price to pay is that we must restrict to space-like compact hypersurfaces S , without boundary and *embedded* in Λ^n . Concretely we will prove that

$$\int_{\mathcal{L}_s} 2 - \#(L_s \cap S) dL_s = \frac{O_{n-2}}{n-1} (\operatorname{vol}(S) - O_{n-1})$$

where the space of space-like lines is denoted by \mathcal{L}_s instead of \mathcal{L}_1^s . Also L_s is one of these lines and dL_s is the invariant measure dL_1^s . We will keep with this simpler notation for

the rest of this text. For the finiteness, it will be seen that outside a compact set of \mathcal{L}_s all the lines meet S in 2 points. If for instance S is the Gauss image of some convex in \mathbb{H}^n , for almost every line the intersection has two points or none. In this case we will be measuring the set of lines disjoint from S .

The assumption for S to be space-like and closed is essential in order to warrant that the integrand vanishes outside a finite measure set.

The proof amounts to study the variational properties of the two members in the equality.

Proposition 2.5.1. *Let S be a closed hypersurface and let $\varphi : S \times (-\epsilon, \epsilon) \rightarrow \Lambda^n$, be a smooth map such that $\varphi_t = \varphi(\cdot, t)$ is a space-like embedding for every t . Assume also that $\langle \partial\varphi/\partial t, \mathbf{n} \rangle < 0$ for some unit normal vector field \mathbf{n} . If $S_t = \varphi_t(S)$ then*

$$\lim_{t \rightarrow 0} \frac{1}{t} \int_{\mathcal{L}_s} (\#(L_s \cap S_0) - \#(L_s \cap S_t)) dL_s = \frac{O_{n-2}}{n-1} \frac{d}{dt} \Big|_{t=0} \text{vol}(S_t).$$

Remark. The assumption on $\partial\varphi/\partial t$ warrants the S_t to be disjoint. This simplifies the proof but it will be clear (*a posteriori*) that this assumption is not necessary.

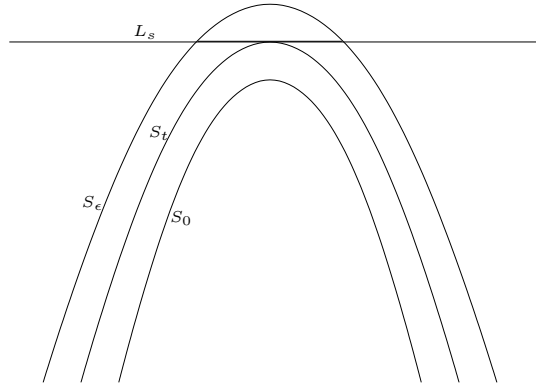

Figure 2.5: Tangent line of type μ^-

Proof. For every line L_s denote by $C(L_s)$ the set of points where L_s is tangent to some hypersurface of the foliation $\{S_t\}_{|t|<\epsilon}$. Now let $\mu^+(L_s)$ be the number of points in $C(L_s)$ such that L_s is locally at the opposite side of \mathbf{n} with respect to S_t . Let $\mu^-(L_s)$ be the number of the rest of the points of $C(L_s)$, and define $\mu(L_s) = \mu^+(L_s) - \mu^-(L_s)$. For ϵ small enough, every interval of $L_s \cap (\cup_t S_t)$ with endpoints in S_0 (not intersecting S_ϵ) has some tangency of the type μ^+ and vice-versa (cf. figure 2.5). For every segment with endpoints in S_ϵ not intersecting S_0 one has a tangent point for μ^- . Thus,

$$\int_{\mathcal{L}_s} (\#(L_s \cap S_0) - \#(L_s \cap S_t)) dL_s = \int_{\mathcal{L}_s} 2\mu dL_s$$

Now consider the map

$$\begin{aligned} \gamma : G_1(S) \times (-\epsilon, \epsilon) &\longrightarrow \mathcal{L}_s \\ ((p, l), t) &\longmapsto \exp_{\varphi_t(p)} l. \end{aligned}$$

Note that $\gamma_t = \gamma(\cdot, t) : G_1(S) \rightarrow \mathcal{L}_s$ coincides with the Gauss map defined in (2.17), and thus the hypersurfaces $\mathcal{L}_s(S_t) = \gamma_t(G_1(S)) \subset \mathcal{L}_s$ consist of tangent lines of S_t . By the area formula

$$2 \int_{\mathcal{L}_s} \mu dL_s = -2 \int_0^\epsilon \int_{G_1(S)} \operatorname{sgn} K(L_s) \gamma^* dL_s.$$

But

$$\gamma^* dL_s = \iota_{\partial t} \gamma^*(dL_s) dt = \gamma_t^*(\iota_{d\gamma \partial t} dL_s) dt.$$

By the fundamental calculus theorem and by virtue of (2.18)

$$\begin{aligned} 2 \lim_{\epsilon \rightarrow 0} \frac{1}{\epsilon} \int_0^\epsilon \int_{G_1(S)} \operatorname{sgn} K(L_s) \gamma_t^*(\iota_{d\gamma \partial t} dL_s) dt &= 2 \int_{G_1(S)} \operatorname{sgn} K(L_s) \gamma_0^*(\iota_{d\gamma \partial t} dL_s) = \\ &= -2 \int_{G_1(S)} \operatorname{sgn} K(L_s) \langle d\gamma \partial_t, N \rangle \gamma_0^*(\iota_N dL_s) = -2 \frac{O_{n-2}}{2} \int_{S_0} \langle d\gamma \partial_t, N \rangle \sigma_1(x) dx \end{aligned}$$

where N is the unit normal field to $\mathcal{L}_s(S_0)$, and this way $\iota_N dL_s$ is the volume element induced by the ambient. The minus sign appears because $\langle d\gamma \partial_t, N \rangle$ is negative, as we will see, and we are working with (positive) densities.

On the other hand, the first variation formula of the volume states (cf. [Spi79])

$$\left. \frac{d}{dt} \right|_{t=0} \operatorname{vol}(S_t) = \int_{S_0} \langle \partial \varphi / \partial t, \mathbf{n} \rangle (n-1) \sigma_1(x) dx$$

where σ_1 denotes the mean curvature of S_0 . Note that we changed one sign in the classical variation formula because $\langle n, n \rangle < 0$.

Take a moving frame $g : G_1(S) \times (-\epsilon, \epsilon) \rightarrow G$ such that $\varphi = \tilde{\pi} \circ g$ i $\gamma = \pi_{n-2} \circ g$. Then,

$$\langle d\gamma \partial t, N \rangle = \langle d\pi_{n-2} \frac{\partial g}{\partial t}, d\pi_{n-2} v_0^n \rangle = \left\langle \frac{\partial g}{\partial t}, v_0^n \right\rangle = \left\langle d\tilde{\pi} \frac{d\varphi}{dt}, \mathbf{n} \right\rangle = \left\langle \frac{\partial \varphi}{\partial t}, \mathbf{n} \right\rangle$$

which is precisely what we needed. □

Corollary 2.5.2. *Let R and S be two space-like hypersurfaces embedded in Λ^n . Then*

$$\int_{\mathcal{L}_s} (\#(L_s \cap S) - \#(L_s \cap R)) dL_s = \frac{O_{n-2}}{n-1} (\operatorname{vol}(R) - \operatorname{vol}(S))$$

Proof. Take $B \subset \mathbb{H}^n$ a ball with a radius big enough so that every hyperplane $L \in R$ meets B . Take the hypersurface $S' \subset \Lambda^n$ consisting of the tangent hyperplanes of ∂B oriented by its outer normal. Consider the bundles of hyperplanes orthogonal to the diameters of B . They foliate Λ^n by time-like geodesics. Since R is space-like, it is

transverse to this foliation. Thus, we can smoothly deform S' into R following the lines of this foliation. Applying the last proposition and integrating we get the result for R and S' .

For arbitrary R and S take a ball B which is big enough for both and the corresponding hypersurface S' . Then we apply the result to R and S' and to S and S' . Finally, we take the difference. \square

Corollary 2.5.3. *[Cauchy-Crofton formula in the de Sitter sphere] Let S be a space like embedded hypersurface in Λ^n . Then*

$$\int_{\mathcal{L}_s} (2 - \#(L_s \cap S)) dL_s = \frac{O_{n-2}}{n-1} (\text{vol}(S) - O_{n-1})$$

Proof. Choose some point $p \in \mathbb{H}^n$ and apply the last corollary with $R = \{L \in \Lambda^n | p \in L\}$. We have finished since almost every space-like line intersects R in two points. \square

Chapter 3

Total Curvature

3.1 The Gauss-Bonnet Theorem in Euclidean Space

In this chapter we study the integral of the Gauss curvature of a closed hypersurface in hyperbolic space. Concretely we will give a proof of the Gauss-Bonnet theorem for such hypersurfaces using the methods of integral geometry. Before it will be convenient to treat the euclidean and spherical cases. In this section we briefly recall the Gauss-Bonnet for hypersurfaces in euclidean space. When this space has odd dimension one has the most known version of this theorem which is due to Hopf.

Theorem 3.1.1. [Hop25] *If $i : S \rightarrow \mathbb{R}^n$ is a C^2 immersion of a closed (compact boundaryless) hypersurface in \mathbb{R}^n with odd n , then the integral of the Gauss curvature of S is*

$$\int_S K dx = \frac{O_{n-1}}{2} \chi(S)$$

where dx is the measure in S induced by i .

It is an almost direct consequence of the Poincaré-Hopf index theorem. We give the proof since it presents some similarities with what will follow.

Proof. Since S is not oriented we consider its unit normal bundle $N(S) = \{(p, n) \in S \times \mathbb{S}^{n-1} \mid n \perp di(T_p S)\}$. There is a Gauss map $\gamma : N(S) \rightarrow \mathbb{S}^{n-1}$ between oriented manifolds defined by $\gamma(p, n) = n$. The curvature of S is defined to be $K = -\det d\gamma$. Note that, being S even dimensional, K has the same value in n and in $-n$. By the area formula

$$\int_S K dx = \frac{1}{2} \int_{N(S)} K dx = -\deg(\gamma) \frac{O_{n-1}}{2}.$$

The proof is reduced to compute $\deg(\gamma)$, the degree of the Gauss map. Let $y, -y \in \mathbb{S}^{n-1}$ regular values of γ . Consider in $N(S)$ the field $X = y - \langle y, \gamma \rangle \gamma$, orthogonal projection of y to the tangent space of $i(S)$. The zeros of X are the points of $\gamma^{-1}(\{y, -y\})$ and are non-degenerate. If X is null in p , then $n = \pm y$ and

$$(dX)_{(p,n)} = -(\text{grad} \langle y, \gamma \rangle)_{(p,n)}^t \cdot n - \langle y, n \rangle (d\gamma)_{(p,n)} = -\langle y, n \rangle (d\gamma)_{(p,n)} \quad (3.1)$$

since $\langle y, \gamma \rangle$ has a maximum or a minimum in (p, n) . In particular $dX(T_p S) \subset di(T_p S)$. Being non-degenerate, the index ι of X in (p, n) is ± 1 , according to the sign of the determinant of the (endomorphism) dX (cf.[Mil97]). But this is $-\det d\gamma$ and by the Poincaré-Hopf theorem,

$$\chi(N(S)) = \sum_{(p,n) \in \gamma^{-1}(\pm y)} \iota(p, n) = -2 \sum_{x \in \gamma^{-1}(y)} \operatorname{sgn}(\det d\gamma)_x = -2 \operatorname{deg} \gamma.$$

The proof is finished since $\chi(N(S)) = 2\chi(S)$. □

The latter theorem need the dimension of the space to be odd but there is a version for arbitrary dimensions. In this case the hypersurface must be assumed to be embedded or equivalently, the boundary of some domain. This theorem is also due to Hopf, though this is not so well known.

Theorem 3.1.2. [Hop27, p.248, Satz VI] *If $S = \partial Q$ is a compact C^2 hypersurface in \mathbb{R}^n , Then the Gauss curvature integral of S , with respect to the inner normal is*

$$\int_S K dx = O_{n-1} \chi(Q). \quad (3.2)$$

Recall that for odd n and $S = \partial Q$ one has $\chi(S) = 2\chi(Q)$. The condition of being boundary is necessary. In general, for odd dimensional immersed hypersurfaces the topology does not determine the curvature integral. For instance, the integral of the curvature of a closed plane curve can take many different values unless it is assumed to be simple.

Next we give the proof of (3.2) that appears in [Got96]. This is again very simple but it uses the following generalization of the Poincaré-Hopf theorem which is due to M. Morse.

Theorem 3.1.3. [Mor29] *Let X be a smooth field in a manifold N with boundary $M = \partial N$. Assume that X has no zero in M and it coincides with the inner normal at isolated points of M . Then the sum $\operatorname{Ind} X$ of the indices at singular points of X is*

$$\operatorname{Ind} X = \chi(N) - \operatorname{Ind}_{\partial} X$$

where $\operatorname{Ind}_{\partial} X$ is the sum of the indices of the projection of X at M in the singular points where X is inward (normal).

Proof (of theorem 3.1.2). As before, it is enough to compute the degree of the Gauss map. But now we choose the Gauss map $\gamma : S \rightarrow \mathbb{S}^{n-1}$ defined by the inner normal. Let $y \in \mathbb{S}^{n-1}$ be a regular value γ . Now apply the latter theorem to the constant field $X \equiv y$ defined on the domain Q . Clearly the points of ∂Q where X is inner normal are the anti-images of y . The equation (3.1) shows that the indices of the projection of X in these points coincides with the sign of $-\det d\gamma$. Therefore, since X nowhere null,

$$\chi(Q) = \operatorname{Ind}_{\partial} X = -\operatorname{deg} \gamma.$$

□

The fact that for even dimensional hypersurfaces one needed only to assume immersion, led Hopf to suspect of the existence of an *intrinsic* Gauss-Bonnet theorem for even dimensional abstract manifolds. Later, Allendoerfer and Fenchel gave a version for even dimensional immersed manifolds with any codimension. Finally Chern proved the Gauss-Bonnet for even dimensional abstract manifolds in [Che44], and a little after he generalized it to manifolds with boundary in [Che45]. Thus, theorem 3.1.1 is a consequence of this intrinsic theorem while theorem 3.1.2 follows from the latter version applied to the manifold with boundary Q .

However, it is good to keep in mind the elementary proof we have just given. Besides of ‘aesthetical’ reasons, note that these extrinsic methods can also derive into some questions, like the study of total absolute curvature, that do not admit intrinsic reformulation.

In the following section we present an extrinsic proof of the Gauss-Bonnet theorem for hypersurfaces of \mathbb{S}^n , which is due to Teufel (cf. [Teu80]) and is based on integral geometry. After taking a look at this proof, it will be clear why the method did not apply to hyperbolic space. However, the same ideas that led to the Cauchy-Crofton formula in the de Sitter sphere will allow us to go on with the hyperbolic case, using also integral geometry. The first step will be to find some variation formulas for the Quermassintegrale W_i that have interest on their own.

Again, we should say that the Gauss-Bonnet theorem in \mathbb{S}^n and \mathbb{H}^n follows easily from the intrinsic version (with boundary if needed). However, in these geometries, even more than in euclidean, some remarkable aspects that appear in the integral geometric proofs, remain hidden when working intrinsically.

Finally, this kind of ideas will lead to a formula for total absolute curvature of a certain class of immersions in hyperbolic space, that will be called *tight*. This result is completely new and will allow to prove the Chern-Lashof inequality holds for tight immersions of tori in hyperbolic space.

3.2 The Gauss-Bonnet Theorem in the sphere

Next, following [Teu80] we relate the total curvature of the boundary of a domain in \mathbb{S}^n to its $(n-2)$ -th Quermassintegrale. Only in the case of odd n the results will generalize to immersions.

Given L_{n-2} an *oriented* geodesic $(n-2)$ -plane of \mathbb{S}^n , consider the bundle of ‘half-hyperplanes’ bounded by it. Parametrizing the bundle by an angle one gets a function

$$h_L : \mathbb{S}^n \setminus L_{n-2} \longrightarrow S^1.$$

Proposition 3.2.1. [Teu80] *Let $i : S \rightarrow \mathbb{S}^n$ be a compact immersed hypersurface oriented through a unit normal vector \mathbf{n} . The curvature integral is given by*

$$M_{n-1}(S) = \frac{n-1}{O_{n-2}} \int_{\mathcal{L}_{n-2}^+} \mu(L_{n-2}, S) dL_{n-2}$$

where \mathcal{L}_{n-2}^+ is the space of oriented $(n-2)$ -planes and $\mu(L_{n-2}, S)$ is the sum of the Morse indexes in the critical points of $h_L \circ i$ where $\text{grad} h_L$ coincides with \mathbf{n} .

Proof. In first place, if $\gamma : S \rightarrow \mathbb{S}^n$ is the Gauss map ($\gamma(x) = \mathbf{n}_x$), the total curvature of S is the (signed) volume of the ‘dual hypersurface’ $\gamma(S)$ (cf. [Teu82])

$$M_{n-1}(S) = \int_{\gamma(S)} \operatorname{sgn}(K(x)) dx.$$

Note that $\gamma(S)$ is smooth out of a null measure set. Now, by the Cauchy-Crofton formula (2.6),

$$\int_{\gamma(S)} \operatorname{sgn}(K(x)) dx = \frac{n-1}{O_{n-2}} \int_{\mathcal{L}_1} \sum_{x \in l \cap \gamma(S)} \operatorname{sgn}(K(x)) dl$$

where \mathcal{L}_1 is the space of great circles l of \mathbb{S}^n . For each circle l determined by a plane P , consider the *polar* $(n-2)$ -plane $L_{n-2} = P^\perp \cap \mathbb{S}^n$. The intersections of l with $\gamma(S)$ correspond to points of S where $\operatorname{grad} h_L$ coincides with \mathbf{n} for some of the two possible orientations of L_{n-2} . Thus,

$$M_{n-1}(S) = \frac{n-1}{O_{n-2}} \int_{\mathcal{L}_{n-2}^+} \sum \operatorname{sgn}(K(x)) dL_{n-2}.$$

where the sum runs over the points x where \mathbf{n} coincides with the gradient of $h_L \circ i$. A computation similar to that of (3.1) shows the sign of K in this points to be the Morse index of $h_L \circ i$. \square

Suppose $S \subset \mathbb{S}^n$ to be a closed embedded hypersurface and let Q be one of the domains bounded by S . Orient S through the unit normal \mathbf{n} interior to Q . For every *generic* $(n-2)$ -plane (i.e. out of a null measure set), the sum of tangency indexes μ is determined by the topology of the intersection between the $(n-2)$ -plane and Q .

Proposition 3.2.2. [Teu80] *If L_{n-2} is an oriented geodesic $(n-2)$ -plane generical position with respect to $S = \partial Q \subset \mathbb{S}^n$ (or \mathbb{R}^n or \mathbb{H}^n) then the index sum in the critical points of $h_L|_S$ where $\operatorname{grad} h_L$ is inwards is*

$$\mu(L_{n-2}, S) = \chi(Q) - \chi(Q \cap L_{n-2}).$$

The following proof is shorter than that of [Teu80] since we use Morse’s theorem 3.1.3.

Proof. Since L is generic we can assume $h_L|_S$ to be a Morse function and also L_{n-2} to be transverse to S . Take a tubular neighbourhood L_{n-2}^ϵ of L_{n-2} not containing any critical point of $h_L|_S$ and in such a way that $L_{n-2}^\epsilon \cap Q$ is a deformation retract of $L_{n-2} \cap Q$. Consider X the gradient of h_L defined in $\mathbb{S}^n \setminus L_{n-2}^\epsilon$. The gradient of the restriction of h_L to S is precisely the orthogonal projection of X to $T_p S$; denote it by ∂X . At singular points, the index of the gradient field of a function equals its Morse index. Thus, $\mu(L_{n-2}, S)$ is the index sum of ∂X in those singular points where X is inwards. Now we apply theorem 3.1.3 to the manifold $N = Q \setminus L_{n-2}^\epsilon$ (or some slight C^∞ modification of it). Since X is nowhere null,

$$\mu(L_{n-2}, S) = \operatorname{Ind}_- \partial X = \chi(N) = \chi(Q \setminus L_{n-2}^\epsilon).$$

By the additivity of the Euler characteristic, we finish the proof with

$$\chi(Q \setminus L_{n-2}^c) = \chi(Q) - \chi(L_{n-2}^c \cap Q) = \chi(Q) - \chi(L_{n-2} \cap Q)$$

since L_{n-2} is a deformation retract of $\chi(L_{n-2}^c)$. \square

In particular we have seen that $\mu(L_{n-2}, S)$ is independent of the orientation of L_{n-2} . Thus, in 3.2.1 no attention should be paid to the orientation of $(n-2)$ -planes and we have

$$M_{n-1}(S) = \frac{2(n-1)}{O_{n-2}} \int_{\mathcal{L}_{n-2}} (\chi(Q) - \chi(L_{n-2} \cap Q)) dL_{n-2}.$$

Since $\mathcal{L}_{n-2} = G(n-1, n+1)$ and

$$\text{vol}(G(r, n)) = \frac{O_{n-1} \cdots O_{n-r}}{O_{r-1} \cdots O_0},$$

from the definition of $W_i(Q)$ we get the following formula.

Corollary 3.2.3. [Teu80] *If $S = \partial Q \subset \mathbb{S}^n$ is differentiable then*

$$M_{n-1}(S) = O_{n-1} \chi(Q) - \frac{n(n-1)}{2} W_{n-2}(Q)$$

This relation can be transported to higher codimensions. That is, the mean curvature integrals are expressed in terms of only two Quermassintegrale. This fact, which is not mentioned in [Teu80], is quite surprising and shows that the relation between mean curvature integrals and Quermassintegrale is much more direct than what equations (2.10) and (2.11) could suggest.

Corollary 3.2.4. *If $S = \partial Q$ is differentiable,*

$$M_r(S) = n \left(W_{r+1}(Q) - \frac{r}{n-r+1} W_{r-1}(Q) \right).$$

Proof. For almost every geodesic r -plane L_r , the intersection $Q \cap L_r$ has smooth boundary. By the previous theorem we have

$$M_{r-1}(S \cap L_r) = O_{r-1} \chi(L_r \cap Q) - \frac{r(r-1)}{2} W_{r-2}(Q \cap L_r).$$

Integrating with respect to L_r ,

$$\begin{aligned} \int_{\mathcal{L}_r} M_{r-1}(S \cap L_r) dL_r &= O_{r-1} \int_{\mathcal{L}_r} \chi(L_r \cap Q) dL_r - \frac{r(r-1)}{2} \int_{\mathcal{L}_r} W_{r-2}(Q \cap L_r) dL_r = \\ &= O_{r-1} \int_{\mathcal{L}_r} \chi(L_r \cap Q) dL_r - \frac{(r-1) \cdot O_0}{O_{r-2}} \int_{\mathcal{L}_r} \int_{\mathcal{L}_{[r](r-2)}} \chi(L_{r-2} \cap Q) dL_{[r](r-2)} dL_r \end{aligned} \quad (3.3)$$

where $\mathcal{L}_{[r](r-2)}$ is the space of $(r-2)$ -planes contained in L_r and $dL_{[r](r-2)}$ is the corresponding measure. But equality (2.5) gives

$$dL_{[r](r-2)}dL_r = dL_{r[r-2]}dL_{r-2}$$

where $dL_{r[r-2]}$ is the natural measure in the space of r -planes containing L_{r-2} . Thus,

$$\int_{\mathcal{L}_r} \int_{\mathcal{L}_{[r](r-2)}} \chi(L_{r-2} \cap Q) dL_{[r](r-2)} dL_r = \frac{O_{n-r+1}O_{n-r}}{O_1O_0} \int_{\mathcal{L}_{r-2}} \chi(L_{r-2} \cap Q) dL_{r-2}.$$

On the other hand, by the reproductive property of the mean curvature integrals (cf. proposition 2.2.4),

$$\int_{\mathcal{L}_r} M_{r-1}(S \cap L_r) dL_r = \frac{O_{n-2} \cdots O_{n-r} O_{n-r+1}}{O_{r-2} \cdots O_0 O_1} M_{r-1}(S).$$

Substituting the two latter equations in 3.3 one gets the desired formula. \square

These formulas lead to a new proof of equations (2.10) and (2.11) for curvature $k = 1$ (and all $k > 0$). It is worthy to say that we have found a completely different way to get this result. Moreover, the classical proof of [San76] made essential use of the Gauss-Bonnet theorem, which we have not used at all.

Proof (of proposition 2.2.5 in \mathbb{S}^n). Use the recurrence

$$W_{r+1}(Q) = \frac{1}{n} M_r(\partial Q) + \frac{r}{n-r+1} W_{r-1}(Q)$$

and finish with

$$W_1(Q) = \frac{1}{n} M_0(\partial Q) \quad W_0(Q) = V \quad W_n(Q) = \frac{O_{n-1}}{n} \chi(Q).$$

\square

But one should remark that when $r = n$ equations (2.10) and (2.11) are the Gauss-Bonnet theorem for embedded hypersurfaces in \mathbb{S}^n ! Let us repeat that classically the Gauss-Bonnet was used to obtain formulas (2.10) and (2.11). Here, we have proved these formulas independently and in particular the Gauss-Bonnet formula. One could also deduce the Gauss-Bonnet theorem directly by induction from corollary 3.2.3 as it is done in [Teu80].

Theorem 3.2.5 (Gauss-Bonnet Theorem in \mathbb{S}^n). *Let $Q \subset \mathbb{S}^n$ be a domain with compact and C^2 boundary ∂Q . If n is even and V denotes the volume of Q ,*

$$c_{n-1}M_{n-1}(\partial Q) + c_{n-3}M_{n-3}(\partial Q) + \cdots + c_1M_1(\partial Q) + V = 1/2O_n\chi(Q).$$

If n is odd,

$$c_{n-1}M_{n-1}(\partial Q) + c_{n-3}M_{n-3}(\partial Q) + \cdots + c_2M_2(\partial Q) + M_0(\partial Q) = 1/2O_n\chi(Q).$$

The constants c_h are

$$c_h = \binom{n-1}{h} \frac{O_n}{O_h O_{n-1-h}}.$$

Immersion

Assume here that $i : S \rightarrow \mathbb{S}^n$ is an immersion (not necessarily embedding) of a hypersurface; i.e. auto-intersections are allowed. To give results analogous to the previous ones, one must restrict the parity of some dimensions. Also, we need some definition.

Definition 3.2.1. Let $i : S \rightarrow \mathbb{S}^n$ (or \mathbb{R}^n or \mathbb{H}^n) be an immersed hypersurface. When r is odd we define

$$W_r(S) = \frac{1}{2} \frac{(n-r)O_{r-1} \cdots O_0}{n \cdot O_{n-2} \cdots O_{n-r-1}} \int_{\mathcal{L}_r} \chi(i^{-1}L_r) dL_r.$$

Note that if $S = \partial Q$ then $W_r(S) = W_r(Q)$ since $\chi(L_r \cap S) = 2\chi(L_r \cap Q)$.

From now on n is assumed to be odd. Proposition 3.2.1 holds for general immersions but we should choose some orientation. Taking the unit normal bundle $N(S) = \{(p, \mathbf{n}) \in \mathbb{S}^n \times \mathbb{S}^n \mid \mathbf{n} \perp di(T_p S)\}$, one has an immersion $i : N(S) \rightarrow \mathbb{S}^n$ and a well defined normal at each point of $N(S)$. Since S is even-dimensional, its curvature is independent of the normal. For the same reason the index of the critical points of the functions $h_L \circ i$ does not depend on the orientation of the $(n-2)$ -planes L_{n-2} . Therefore,

$$\begin{aligned} \int_S K dp &= \frac{1}{2} \int_{N(S)} K dp = \\ &= \frac{n-1}{2O_{n-2}} \int_{\mathcal{L}_{n-2}^+} \mu(L_{n-2}, S) dL_{n-2} = \frac{n-1}{O_{n-2}} \int_{\mathcal{L}_{n-2}} \mu(L_{n-2}, S) dL_{n-2} \end{aligned} \quad (3.4)$$

where, in the case of non-oriented L_{n-2} , the index sum $\mu(L_{n-2}, S)$ is over *all* the critical points of $h_L \circ i$. About proposition 3.2.2, this makes reference to the interior domain which only exists for embeddings. Thus, we must replace it by the following proposition.

Proposition 3.2.6. Let $i : S \rightarrow \mathbb{S}^n$ (or \mathbb{R}^n or \mathbb{H}^n) be an immersed hypersurface and L_{n-2} a (non-oriented) $(n-2)$ -plane in generic position with respect to $i(S)$. The index sum of the restriction $h_L \circ i$ is

$$\mu(S, L_{n-2}) = \chi(S) - \chi(i^{-1}L_{n-2}) \quad (3.5)$$

Here n needs not to be odd. For even n , since $\chi(S) = \chi(i^{-1}L_{n-2}) = 0$, we get that the total index sum of $h_L \circ i$ is always 0.

Proof. Consider the gradient field X of $h_L \circ i$ defined in S . Since L_{n-2} is in generic position, we can choose a tubular neighbourhood L_{n-2}^ϵ not containing any zero of diX . Set $N = S \setminus i^{-1}L_{n-2}$. Note that X is nowhere orthogonal to ∂N . By Morse's formula, the index sum of X in N is

$$\mu(S, L_{n-2}) = \chi(N) = \chi(S \setminus i^{-1}L_{n-2}^\epsilon) = \chi(S) - \chi(i^{-1}L_{n-2}^\epsilon) = \chi(S) - \chi(i^{-1}L_{n-2})$$

since, for ϵ small enough, $i^{-1}L_{n-2}^\epsilon$ is a deformation retract of $i^{-1}L_{n-2}$. \square

Substituting (3.5) in (3.4) one gets, for odd n ,

$$\begin{aligned} M_{n-1}(S) &= \frac{n-1}{O_{n-2}} \left(\frac{O_n O_{n-1}}{O_1 O_0} \chi(S) - \int_{\mathcal{L}_{n-2}} \chi(i^{-1}L_{n-2}) dL_{n-2} \right) = \\ &= nW_n(S) - \frac{n(n-1)}{2} W_{n-2}(S). \end{aligned}$$

As for embeddings one can use the reproductive properties to get

$$M_r(S) = n \left(W_{r+1}(S) - \frac{r}{n-r+1} W_{r-1}(S) \right).$$

Therefore, we deduce formula (2.11) also for immersed hypersurfaces since the planes involved there are odd-dimensional. In particular, we have also proved the Gauss-Bonnet theorem for immersed hypersurfaces in odd-dimensional spheres.

At this point, the most natural willing is to repeat the process in hyperbolic space. The first step would be to relate total curvature to the volume of the Gauss map. We have seen in chapter 2 that this works in hyperbolic space the same as in euclidean or spherical. The only peculiarity is that in hyperbolic case, the Gauss map has its target space in the de Sitter sphere. Next step should be to use the Cauchy-Crofton to compute this volume. It is clear that difficulties appear at this stage. It has been already said that the usual Cauchy-Crofton formula does not hold in the de Sitter sphere. An alternative version of this formula was given in [Teu82]. This formula led to a way to compute the total curvature of immersions in hyperbolic space. However this method did not lead to the Gauss-Bonnet theorem.

Thus, having found a new alternative to Cauchy-Crofton for space-like embedded hypersurfaces in the de Sitter sphere, we should be hopeful. We can not use directly theorem 2.5.3 since the Gauss image is not an immersion (may degenerate in some point). However, in the two following sections we use the ideas of section 2.5 to complete this study of total curvature in hyperbolic space.

3.3 Variation Formulas.

Let us make a little parenthesis to find some first variation formulas. They will be the key to continue the study of total curvature, but in addition they have interest on their own. Concretely we study the variation of Quermassintegrale $W_r(Q)$ when the domain Q is perturbed. If a plane L_r cuts ∂Q transversally, after an infinitesimal perturbation of Q , the intersection $Q \cap L_r$ will not change its topology. Thus, it is clear that the variation of $W_r(Q)$ will be related to the measure of tangent r -planes. Therefore we will need the results of section 2.4.

We are mainly interested in hyperbolic space but all all what we do in this section holds in \mathbb{R}^n and \mathbb{S}^n . Thus, we work in the three geometries at the same time without need of any additional remark.

Let us start in the following situation. Let $\varphi : Q \times I \longrightarrow \mathbb{H}^n$ (o \mathbb{R}^n , o \mathbb{S}^n) be a smooth mapping such that for every $t \in I = (-\epsilon, \epsilon)$, the restriction $\varphi_t = \varphi(\cdot, t)$ is injective. We denote $Q_t = \varphi_t(Q)$ and call them a *deformation* of Q_0 . It is clear that φ_t is an embedding of $S = \partial Q$ and that the image $S_t = \varphi_t(S) = \partial Q_t$.

Proposition 3.3.1. *If Q_t is a deformation of a domain Q_0 , then for a generic r -plane L_r and $0 < t_0 < \epsilon$*

$$\chi(L_r \cap Q_{t_0}) - \chi(L_r \cap Q_0) = - \sum \operatorname{sgn} \left\langle \frac{\partial \varphi}{\partial t}, \mathbf{n} \right\rangle \operatorname{sgn} K(L_r)$$

where the sum is taken over the points $\varphi_t(x)$ where L_r is tangent to S_t for some $t \in (0, t_0)$, and $K(L_r)$ is the normal curvature of S_t in the direction $T_{\varphi(x,t)}L_r$ with respect to the inner normal \mathbf{n} .

Proof. Consider $Q \times I \longrightarrow \mathbb{H}^n \times I$ defined by $(p, t) \mapsto (\varphi(p, t), t)$. By hypothesis, the image is a domain M of $\mathbb{H}^n \times I$. Reduce for the moment I to $(0, t_0)$. Then $\partial M \subset (\mathbb{H}^n \times I)$ is smooth. For a generic L_r we can suppose $L_r \times I$ to be transverse to this hypersurface. Thus, $N = M \cap (L_r \times I)$ is a domain of $L_r \times I$ with smooth boundary (cf. figure 3.1). Consider the unit vertical field ∂t and its orthogonal projection onto ∂N

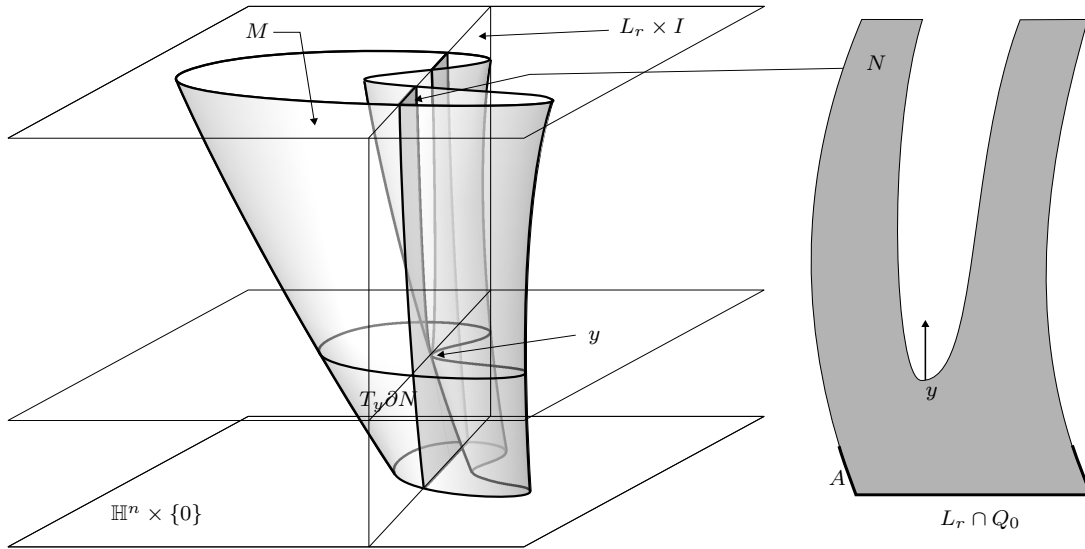

Figure 3.1: Deformation d'un domini

$$X = \partial t - \langle \partial t, \mathbf{n}' \rangle \mathbf{n}'$$

where \mathbf{n}' is the inner unit normal to ∂N . Let us place on a singular point $y = \varphi_t(p) \in \partial N$ of X . Next we compute the index ι of X in y . Let $dX : T_y \partial N \rightarrow T_y \partial N$ be the map sending $Z \mapsto \nabla_Z X$ where ∇ is the Levi-Civita connection on $L_r \times I$. Similarly to (3.1)

we have,

$$dX(Z) = \nabla_Z X = \nabla_Z \partial t - \nabla_Z \langle \partial t, \mathbf{n}' \rangle \mathbf{n}' = Z(\langle \partial t, \mathbf{n}' \rangle) \mathbf{n}' - \langle \partial t, \mathbf{n}' \rangle \nabla_Z \mathbf{n}' = -\langle \partial t, \mathbf{n}' \rangle \nabla_Z \mathbf{n}' \quad (3.6)$$

and by hypothesis $\partial t = \pm \mathbf{n}'$. Thus, the determinant of dX is, up to the sign, the Gauss curvature K' of ∂N in y as a hypersurface of $L_r \times I$ and with respect to \mathbf{n}'

$$\det dX = \langle \partial t, \mathbf{n}' \rangle^r K'.$$

Since \mathbf{n}' is inwards to M , by theorem 1.2.2 (Meusnier), K' is a positive multiple of the normal curvature of ∂M in the direction $T_y \partial N$ with respect to the inner normal to ∂M . For the same reason, this normal curvature is a positive multiple of $K(L_r)$, the normal curvature of $S_t \equiv (\mathbb{H}^n \times \{t\}) \cap \partial M$ with respect to \mathbf{n} in the direction $T_p L_r$. In particular, y is a degenerate singular point if and only if S_t has normal curvature 0 at x in the direction of L_r . For almost all L_r , the singularities are non-degenerate, and thus isolated. To see this, it is enough to apply the Sard-Federer theorem (cf.[Fed69]) to the mapping $G_r(S) \times I \rightarrow \mathcal{L}_r$ defined by $((p, V), t) \mapsto \exp_{\varphi(p,t)} V$. Its critical values are the r -planes which are tangent to some S_t in such a way that $K(L_r) = 0$. Therefore, the set of such r -planes, which are precisely those which give degenerate singularities of X , has null measure.

Therefore, for almost every L_r we can assume all the singular points y of X to be degenerate. Thus (cf. [Mil97]), their index is ± 1 according to the sign of the determinant of dX , or

$$\iota(y) = \text{sgn} \det dX_y = \langle \partial t, \mathbf{n}' \rangle^r \text{sgn} K(L_r) \quad (3.7)$$

where $K(L_r)$ is the normal curvature of S_t in the direction $T_y L_r$.

We now want to relate $\chi(L_r \cap Q_{t_0}) - \chi(L_r \cap Q_0)$ to the index sum of X . First we extend I to $[0, t_0]$ and we slightly modify N in such a way that the new boundary ∂N in $\mathbb{H}^n \times I$ is smooth. This modification can be made outside the region $N \cap (L_r \times [\delta, t_0 - \delta])$ for a small δ . Moreover, we can assume the new ∂N to be orthogonal to ∂t only at isolated points. Consider the open set $A = \partial N \cap (L_r \times [0, \delta])$ in ∂N . The field X , orthogonal projection of ∂t on ∂N , is outwards to A at ∂A . By the Poincaré-Hopf theorem (with boundary), $\chi(A)$ is the index sum of X in the singular points contained in A . Applying theorem 3.1.3, we get

$$\chi(N) = \sum_{C^+} \iota = \sum_{C^+ \cap A} \iota + \sum_{C^+ \setminus A} \iota = \chi(A) + \sum_{C^+ \setminus A} \iota$$

where C^+ is the set of singular points of the projection of ∂t where it is interior, and ι is the index of such singular points. That is

$$\chi(L_r \cap Q_0) = \chi(N) - \sum_{C^+ \cap (\delta, t_0 - \delta)} \iota.$$

Analogously one sees

$$\chi(L_r \cap Q_{t_0}) = \chi(N) - \sum_{C^- \cap (\delta, t_0 - \delta)} \iota'$$

where the points in C^- are singularities of $-X$ where ∂t is interior and ι' is its index. Since $\iota' = (-1)^r \iota$,

$$\chi(L_r \cap Q_{t_0}) - \chi(L_r \cap Q_0) = - \sum_{C^-} \iota' + \sum_{C^+} \iota = \sum_C \langle \partial t, \mathbf{n}' \rangle^{r+1} \iota$$

where $C = C^+ \cup C^-$ and \mathbf{n}' is the inner normal to ∂N . We finish the proof substituting (3.7) in the latter equation and noting that ∂t is interior to M if and only if $\partial\varphi/\partial t$ is exterior to Q_t . \square

With this proposition we can prove the first variation formula for the Quermassintegrals of a domain with smooth boundary in \mathbb{H}^n (or \mathbb{R}^n or \mathbb{S}^n).

Theorem 3.3.2. *For a deformation of domains Q_t ,*

$$\begin{aligned} \frac{n \cdot O_{n-2} \cdots O_{n-r-1}}{(n-r) \cdot O_{r-1} \cdots O_0} \frac{d}{dt} \Big|_{t=0} W_r(Q_t) &= \\ &= \frac{d}{dt} \Big|_{t=0} \int_{\mathcal{L}_r} \chi(L_r \cap Q_t) dL_r = -\text{vol}(G(r, n-1)) \int_{S_0} \phi(x) \sigma_r(x) dx \end{aligned}$$

where $\phi(x) = \langle \partial\varphi/\partial t, \mathbf{n} \rangle$ and \mathbf{n} is the inner unit normal.

Proof. By the previous proposition, for almost all L_r we have

$$\chi(L_r \cap Q_t) - \chi(L_r \cap Q_0) = - \sum \text{sgn} \phi \text{sgn} K(L_r)$$

where the sum is over the tangencies of L_r with the hypersurfaces S_t , and $K(L_r)$ is the normal curvature of S_t in the direction L_r with respect to \mathbf{n} . Integrating with respect to L_r ,

$$\int_{\mathcal{L}_r} (\chi(L_r \cap Q_t) - \chi(L_r \cap Q_0)) dL_r = - \int_{\mathcal{L}_r} \sum \text{sgn} \phi \text{sgn} K(L_r) dL_r.$$

Consider

$$\begin{aligned} \gamma : G_r(S) \times (-\epsilon, \epsilon) &\longrightarrow \mathcal{L}_r \\ ((x, V_r), t) &\longmapsto \exp_{\varphi_t(x)} V_r \end{aligned}$$

and the hypersurfaces $\mathcal{L}_r(S_t) = \gamma(G_r(S), t) \subset \mathcal{L}_r$. By the area formula,

$$\int_{\mathcal{L}_r} \sum \text{sgn} \phi \text{sgn} K(L_r) dL_r = \int_0^t \int_{G_r(S)} \text{sgn} \phi \text{sgn} K(L_r) \gamma_t^* \iota_{d\gamma} \partial t dL_r dt$$

where $\gamma_t = \gamma(\cdot, t)$. By the fundamental theorem of calculus

$$\begin{aligned} \frac{d}{dt} \Big|_{t=0} \int_0^t \int_{G_r(S)} \text{sgn} \phi \text{sgn} K(L_r) \gamma_t^* \iota_{d\gamma} \partial t dL_r dt &= \int_{G_r(S)} \text{sgn} \phi \text{sgn} K(L_r) \gamma_0^* \iota_{d\gamma} \partial t dL_r = \\ &= \int_{G_r(S)} \text{sgn} \phi \text{sgn} K(L_r) |\langle d\gamma \partial t, \mathbf{N} \rangle| \gamma_0^* \iota_{\mathbf{N}} dL_r \end{aligned}$$

where N is the unit normal field to $\mathcal{L}_r(S_0)$. Indeed,

$$\iota_{d\gamma\partial t}dL_r = |\langle d\gamma\partial t, N \rangle| \iota_N dL_r$$

since we are dealing with densities. Note that $\iota_N dL_r$ is the volume element of $\mathcal{L}_r(S_t)$ induced by the ambient.

Now take a ‘moving frame’ $g : (-\epsilon, \epsilon) \times G_r(S) \rightarrow G$ such that $\varphi = \pi \circ g$, $\gamma = \pi_r \circ g$ and g_n coincides with n . Then

$$\langle d\gamma\partial t, N \rangle = \langle d\pi_r \frac{\partial g}{\partial t}, d\pi_r v_0^n \rangle = \langle \frac{\partial g}{\partial t}, v_0^n \rangle = -\langle d\pi \frac{\partial g}{\partial t}, d\pi v_0^n \rangle = -\langle \partial\varphi/\partial t, n \rangle = -\phi. \quad (3.8)$$

Thus,

$$\frac{d}{dt} \Big|_{t=0} \int_{\mathcal{L}_r} \chi(L_r \cap Q_t) dL_r = - \int_{G_r(S)} \phi \operatorname{sgn}K(L_r) \gamma_0^* \iota_N dL_r$$

Finally by corollary 2.4.2

$$- \int_{G_r(S)} \phi \operatorname{sgn}K(L_r) \gamma_0^* \iota_N dL_r = -\operatorname{vol}(G(r, n-1)) \int_{S_0} \phi \sigma_r(x) dx.$$

□

As in the previous section, we can extend this results to immersions if we restrict the parity of some dimensions. Thus, suppose $i : S \times I \rightarrow \mathbb{H}^n$ a smooth mapping such that for each $t \in I = (-\epsilon, \epsilon)$, the restriction $i_t = i(\cdot, t)$ is an immersion (not necessarily embedding) of a closed hypersurface S . We will say that we have a *deformation* of the immersion i_0 . In this setting we have variation formulas for the Quermassintegrale $W_r(S)$ with odd r (cf. definition 3.2.1). Before we will need the following proposition.

Proposition 3.3.3. *For an immersions deformation i_t , if r is odd and L_r is a generic r -plane,*

$$\chi(i_{t_0}^{-1}L_r) - \chi(i_0^{-1}L_r) = -2 \sum \operatorname{sgn}K(L_r)$$

where the sum is taken over the contact points $i_t(p)$ of L_r with S_t for some $t \in (0, t_0)$, and $K(L_r)$ is the normal curvature of S_t in the direction $T_{i(p,t)}L_r$ with respect to the unit normal n that makes $\langle \partial i/\partial t, n \rangle > 0$.

Proof. Reduce I to $[0, t_0]$. Let $\Phi : S \times I \rightarrow \mathbb{H}^n \times I$ be defined by $\Phi(x, t) = (i_t(x), t)$. The image of Φ is an immersed hypersurface of $\mathbb{H}^n \times I$. By the genericity hypothesis we can assume $L_r \times I$ to be transverse to this image. Then, $N = \Phi^{-1}(L_r \times I)$ is a hypersurface of $S \times I$. Consider the gradient field X of the function t restricted to N . Let $y = (p, t) \in N$ be a singular point of X . Since Φ is injective in a neighborhood U of y , we can identify U to $\Phi(U) \subset \mathbb{H}^n \times I$. Also, $d\Phi X$ is the orthogonal projection of ∂t to $\Phi(U)$. Equation (3.6) shows that for all $Y \in T_y N$

$$dX(Y) = -\nabla_Y n'$$

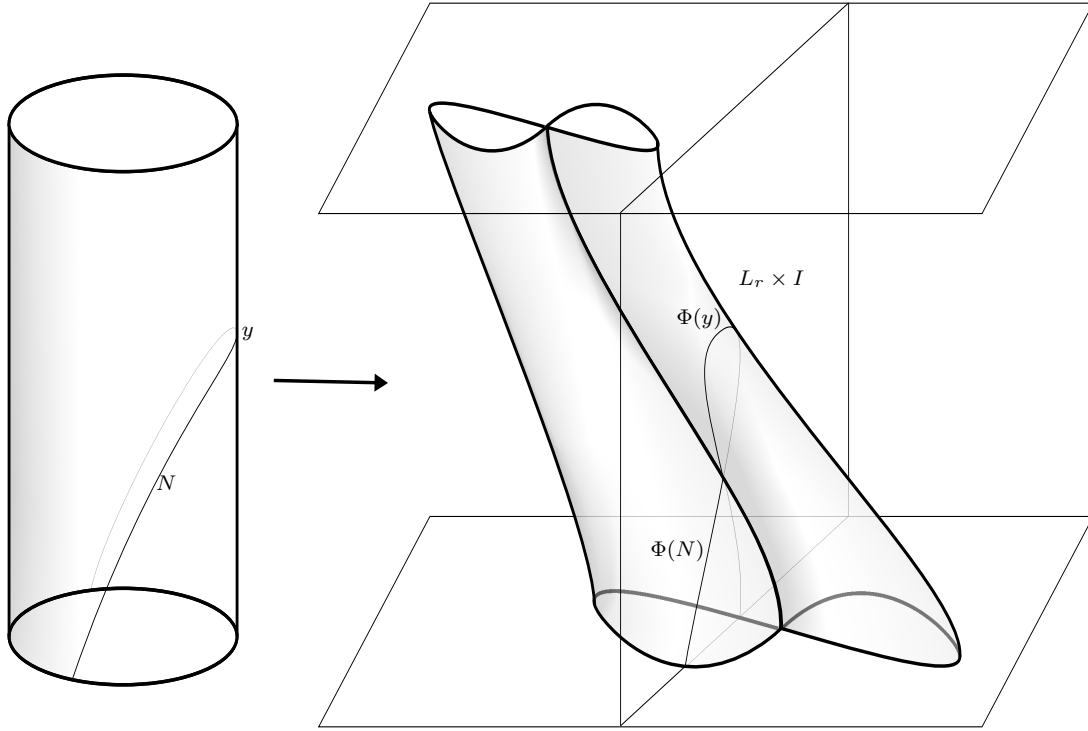

Figure 3.2: Deformation of an immersion

where n' is the unit normal vector that coincides with ∂t at y . Therefore, the determinant of dX in y is the Gauss curvature K' of $\Phi(U)$ as a hypersurface on $L_r \times I$ with respect to the unit normal n' . Let n'' be the unit normal to $\Phi(S \times I)$ such that $\langle \partial i / \partial t, n'' \rangle > 0$. Since $\Phi(N) = \Phi(S \times I) \cap (L_r \times I)$, theorem 1.2.2 (Meusnier) states that K' is a negative multiple of the normal curvature of $\Phi(S \times I)$ with respect to n'' in the direction $T_{(\Phi(y))}(L_r \times \{t\}) = T_{(\Phi(y))}\Phi(N)$. The same theorem gives that this normal curvature is a positive multiple of $K(L_r)$, the normal curvature of $i_t(S)$ as a hypersurface of $\mathbb{H}^n \times \{t\}$ in the direction $T_p L_r$ with respect to the normal vector of the statement. Thus,

$$\det dX = -K(L_r)$$

and so, using the Sard-Federer theorem, for almost all L_r the normal curvature $K(L_r) \neq 0$ in the contact points and thus the singular points of X are non-degenerate and isolate. In such case we have seen the index of X to be

$$\iota = -\text{sgn}K(L_r).$$

Applying theorem 3.1.3 to X and $-X$, we get

$$\sum_C \iota = \chi(N) - \sum_{D_0} v$$

$$-\sum_C \iota = \chi(N) - \sum_{D_{t_0}} v$$

where C is the set of singular points of the field X and ι is the index of these singularities. We have used the oddness of the dimension of N to deduce the index of $-X$ to be opposite to that of X . Similarly, D_t is the set of singularities of the projection of X to $i_t^{-1}(L_r) \times \{t\}$ and v is the index of each point. Even if these singularities are not isolated, this can be fixed by extending I to $[-\delta, t_0 + \delta]$ (for small $\delta > 0$) and extending also X to $S \times I$ properly.

Subtracting and using the Poincaré-Hopf theorem we get

$$-2 \sum_C \text{sgn}K(L_r) = 2 \sum_C \iota = \sum_{D_t} v - \sum_{D_0} v = \chi(i_t^{-1}L_r) - \chi(i_0^{-1}L_r)$$

as was to be proved. □

From this proposition, a proof analogous to that of theorem 3.3.2 gives the following

Theorem 3.3.4. *For a deformation i_t of immersions of S , if r is odd,*

$$\begin{aligned} \frac{n \cdot O_{n-2} \cdots O_{n-r-1}}{(n-r)O_{r-1} \cdots O_0} \frac{d}{dt} \Big|_{t=0} W_r(S_t) &= \\ &= \frac{1}{2} \frac{d}{dt} \Big|_{t=0} \int_{\mathcal{L}_r} \chi(i_t^{-1}L_r) dL_r = -\text{vol}(G(r, n-1)) \int_{S_0} \langle \partial i / \partial t, n \rangle \sigma_r(x) dx \end{aligned}$$

where n is any unit normal and σ_r is the mean curvature with respect to it.

When the immersions are embeddings, this theorem coincides with theorem 3.3.2.

3.4 The Gauss-Bonnet Theorem in Hyperbolic space

In this section we relate the total curvature of a closed hypersurface in hyperbolic space to its $(n-2)$ -th Quermassintegrale. The basic ideas are the same as in spherical case although technically it is quite different. The result is a formula analogous to (3.2.3) which is equivalent to the Gauss-Bonnet theorem although it is much more simple.

Lemma 3.4.1. *Suppose a deformation of one of the two treated kinds. That is*

- i) let Q be an n -dimensional manifold with boundary S and suppose $\varphi : Q \times (-\epsilon, \epsilon) \rightarrow \mathbb{H}^n$, a smooth mapping such that $\varphi_t = \varphi(\cdot, t)$ is embedding for every t , or*
- ii) let S be a compact manifold of even dimension $n-1$ and suppose a smooth mapping $\varphi : S \times (-\epsilon, \epsilon) \rightarrow \mathbb{H}^n$ such that $\varphi_t = \varphi(\cdot, t)$ is an immersion for every t .*

In both cases assume that the Gauss curvature $K_t(x)$ of S_t in $\varphi_t(x)$ does not change its sign with t . Then, for case i) we have

$$\frac{d}{dt} \Big|_{t=0} \int_{\mathcal{L}_{n-2}} \chi(Q_t \cap L_{n-2}) dL_{n-2} = \frac{O_{n-2}}{2(n-1)} \frac{d}{dt} \Big|_{t=0} \int_{S_t} K_t(x) dx, \quad (3.9)$$

and for case *ii*)

$$\frac{d}{dt} \Big|_{t=0} \int_{\mathcal{L}_{n-2}} \chi(\varphi_t^{-1} L_{n-2}) dL_{n-2} = \frac{O_{n-2}}{n-1} \frac{d}{dt} \Big|_{t=0} \int_{S_t} K_t(x) dx. \quad (3.10)$$

Remark. The integrals on the left are finite since the integrand vanishes outside a compact set. On the other hand, we will see *a posteriori* that the assumption that K_t does not change its sign is superfluous.

Proof. Let us do only the case *i*) since the proof for *ii*) is identical. By theorem 3.3.2, denoting $S = \partial Q$,

$$\frac{d}{dt} \Big|_{t=0} \int_{\mathcal{L}_{n-2}} \chi(Q_t \cap L_{n-2}) dL_{n-2} = -\frac{O_{n-2}}{2} \int_{S_0} \langle \partial\varphi/\partial t, \mathbf{n} \rangle \sigma_{n-2}(x) dx. \quad (3.11)$$

On the other hand, let

$$\begin{aligned} \gamma : S \times (-\epsilon, \epsilon) &\longrightarrow \Lambda^n \\ (x, t) &\longmapsto \exp_{\varphi_t(x)}(T_x S). \end{aligned}$$

and let $U = \{x \in S \mid K_t(x) \geq 0 \ \forall t\}$. Take a sequence (U_r) of compact sets in U with smooth boundary such that $K_t(x) > 0$ for all $x \in U_r$ and all $t \in (-\epsilon, \epsilon)$, and such that $\sup\{K_t(x) \mid x \in \partial U_r, t \in (-\epsilon, \epsilon)\}$ goes to 0 as $r \rightarrow \infty$. By the Leibniz rule and the dominated convergence theorem,

$$\frac{d}{dt} \Big|_{t=0} \int_U K_t dx = \int_U \frac{d}{dt} \Big|_{t=0} (K_t dx) = \lim_{r \rightarrow \infty} \int_{U_r} \frac{d}{dt} \Big|_{t=0} K_t dx = \lim_{r \rightarrow \infty} \frac{d}{dt} \Big|_{t=0} \int_{U_r} K_t dx$$

But by (2.15), if $d\tilde{x}$ denotes the volume element of $\gamma_t(S)$,

$$K_t dx = \gamma^* d\tilde{x} \quad (3.12)$$

and so

$$\int_{U_r} K_t dx = \int_{\gamma(t, U_r)} d\tilde{x}.$$

Since $\gamma_t = \gamma(t, \cdot) : U_r \rightarrow \Lambda^n$ is immersion at every $t \in (-\epsilon, \epsilon)$ we can apply the first variation formula of volume (cf. [Spi79, p. 418])

$$\frac{d}{dt} \Big|_{t=0} \int_{U_r} K_t dx = (n-1) \int_{\gamma_0(U_r)} \langle d\gamma \partial t, N \rangle \tilde{\sigma}_1 d\tilde{x} + \int_{\partial U_r} \gamma^* \iota_X d\tilde{x}$$

where X is the tangent part of the variation vector $d\gamma \partial t$. Since $\sup_{\partial U_r} K_t$ goes to 0 as r grows we have that $\gamma^* d\tilde{x}$ also goes to 0 on this boundary and remains

$$\frac{d}{dt} \Big|_{t=0} \int_U K_t dx = (n-1) \int_{\gamma_0(U_0)} \langle d\gamma \partial t, N \rangle \tilde{\sigma}_1 d\tilde{x} = (n-1) \int_{U_0} \langle d\gamma \partial t, N \rangle \sigma_{n-2} dx \quad (3.13)$$

since $\sigma_{n-2} = K \tilde{\sigma}_1$ by corollary 2.3.9. For the negatively curved part one proceeds analogously. By equation (3.8) we have $\langle d\gamma \partial t, N \rangle = -\langle \partial\varphi/\partial t, \mathbf{n} \rangle$ and comparing (3.11) with (3.13) we see that that was precisely the needed equality. \square

Now the idea is to shrink any hypersurface up to almost collapse it to a point, and integrate equations (3.9) and (3.10) with respect to t during this deformation.

Theorem 3.4.2. *Let S be a hypersurface of \mathbb{H}^n bounding a domain Q . Then,*

$$\int_{\mathcal{L}_{n-2}} \chi(L_{n-2} \cap Q) dL_{n-2} = \frac{O_{n-2}}{2(n-1)} (M_{n-1}(S) - O_{n-1}\chi(Q)).$$

If $i : S \rightarrow \mathbb{H}^n$ is an immersed hypersurface with odd n ,

$$\int_{\mathcal{L}_{n-2}} \frac{\chi(i^{-1}L_{n-2})}{2} dL_{n-2} = \frac{O_{n-2}}{2(n-1)} \left(M_{n-1}(S) - \frac{O_{n-1}\chi(S)}{2} \right).$$

Proof. Let us restrict to the first case. Suppose S in the projective (or Klein) model of \mathbb{H}^n . Through homotheties deform homotopically S to get $S' = \partial Q'$ contained in a ball of arbitrarily small radius. Since the sign of the euclidean curvature of S is invariant under, by proposition 1.2.3 the hyperbolic curvature does neither change its sign. Thus, we can apply the previous proposition to get

$$\int_{\mathcal{L}_{n-2}} (\chi(L_{n-2} \cap Q) - \chi(L_{n-2} \cap Q')) dL_{n-2} = \frac{O_{n-2}}{2(n-1)} (M_{n-1}(S) - M_{n-1}(S')).$$

Since the metric of a small ball is almost euclidean and the curvature depends continuously on the metric, $M_{n-1}(S')$ is as close to $O_{n-1}\chi(Q)$ as we want (cf. teorema 3.1.2). On the other hand, $\chi(L_{n-2} \cap Q') = 0$ when L_{n-2} does not intersect the small ball. \square

Thus we obtain the following formulas which are analogous to that of corollary 3.2.3 and will lead to (2.10), (2.11) and in particular to the Gauss-Bonnet theorem in \mathbb{H}^n .

Corollary 3.4.3. *If $Q \subset \mathbb{H}^n$ is a domain with smooth boundary, then*

$$M_{n-1}(\partial Q) = n(W_n(Q) + fracn - 12W_{n-2}(Q)).$$

If S is an immersed hypersurface and n is odd then

$$M_{n-1}(S) = n(W_n(S) + fracn - 12W_{n-2}(S)).$$

Proof. Multiply the equations in the preceding proposition by the constants appearing in definitions 2.2.1 and 3.2.1 of the Quermassintegrale. \square

These formulas can be moved to higher codimensions using reproductibility.

Corollary 3.4.4. *If $Q \subset \mathbb{H}^n$ is a domain with smooth boundary S , then*

$$M_r(S) = n \left(W_{r+1}(Q) + \frac{r}{n-r+1} W_{r-1}(Q) \right). \quad (3.14)$$

If S is a hypersurface and r is odd, then

$$M_r(S) = n \left(W_{r+1}(S) + \frac{r}{n-r+1} W_{r-1}(S) \right).$$

Proof. Identical to that of the spherical case (cf. corollary 3.2.4). \square

From here we have a new proof of formulas (2.10) and (2.11) for curvature $k = -1$ (and $k < 0$).

Proof (of proposition 2.2.5 in \mathbb{H}^n). Use the recurrence

$$W_{r+1}(Q) = \frac{1}{n}M_r(\partial Q) - \frac{r}{n-r+1}W_{r-1}(Q)$$

and finish with

$$W_1(Q) = \frac{1}{n}M_0(\partial Q) \quad W_0(Q) = V \quad W_n(Q) = \frac{O_{n-1}}{n}\chi(Q)$$

\square

Remark. The same formulas hold for immersions if r is odd.

As a particular case, if $r = n$ we get the Gauss-Bonnet theorem.

Theorem 3.4.5 (Gauss-Bonnet theorem in \mathbb{H}^n). *Let $Q \subset \mathbb{H}^n$ be a domain with C^2 compact boundary $S = \partial Q$. If n is even and V denotes the volume of Q ,*

$$c_{n-1}M_{n-1}(S) + c_{n-3}M_{n-3}(S) + \cdots + c_1M_1(S) + (-1)^{n/2}V = O_n\chi(Q)/2.$$

If n is odd, even if S is just immersed,

$$c_{n-1}M_{n-1}(S) + c_{n-3}M_{n-3}(S) + \cdots + c_2M_2(S) - M_0(S) = O_n\chi(S)$$

where the constants c_h are

$$c_h = \binom{n-1}{h} \frac{(-1)^{(n-h-1)/2}O_n}{O_hO_{n-1-h}}.$$

We finish the section with some remarks about convex sets. Recall that the total curvature of the (possibly non-smooth) boundary of a convex set equals the measure of its support planes. It has also been said that with this definition the total curvature is a continuous functional in the space of convex set with respect to the Hausdorff metric. No need to say that the Quermassintegrale W_r make sense and are continuous in this space. Therefore, the next proposition is immediate by approximating a convex set by a sequence of smooth convex domains.

Proposition 3.4.6. *If $Q \subset \mathbb{H}^n$ is a compact convex set then,*

$$M_{n-1}(\partial Q) = O_{n-1} + \frac{n(n-1)}{2}W_{n-2}(Q).$$

About mean curvature integrals, given an arbitrary convex $Q \subset \mathbb{H}^n$ we can take (3.14) as a definition of $M_i(\partial Q)$. This way, all the M_i are continuous functionals with respect to the Hausdorff metric. Moreover, we immediately have the following result that may be new.

Corollary 3.4.7. *The mean curvature integrals $M_i(\cdot)$ are increasing functionals (with respect to inclusion) in the space of compact convex sets.*

3.5 Total Absolute Curvature in Hyperbolic Space

This section is devoted to the study of total absolute curvature of immersions in hyperbolic space. We start with surfaces in \mathbb{H}^3 . We give some inequalities and construct examples showing that the Chern-Lashof inequality does not hold in \mathbb{H}^3 for connected sums of 2 or more tori. Then we go to higher dimensions where exploding the ideas of the previous sections, we obtain a formula for the computation of total absolute curvature of a *tight* immersion in \mathbb{H}^n . But before, it is convenient to start recalling briefly the subject in euclidean space.

3.5.1 Total Absolute Curvature in Euclidean Space

We recall the definition of total absolute curvature in \mathbb{R}^n as well as the Chern-Lashof inequality. If $i : S \rightarrow \mathbb{R}^n$ is an r -dimensional submanifold immersed in \mathbb{R}^n , the total absolute curvature of S is defined as the integral on the unit normal bundle of $i(S)$ of the absolute value of the Lipschitz-Killing curvature $K(x, n)$

$$\text{TAC}(S) := \frac{1}{2} \int_{N(S)} |K(x, n)| \, dndx.$$

Thus, if for instance S is a hypersurface, $\text{TAC}(S)$ is the integral of the absolute value of the curvature of S . The Chern-Lashof inequality (cf. [CL57]) states that for every compact $(n-2)$ -submanifold S immersed in \mathbb{R}^n one has

$$\text{TAC}(S) \geq \frac{O_{n-1}}{2} \beta(S, F) \quad (3.15)$$

where $\beta(S, F) = \sum \beta_i(S, F) = \sum \dim H_i(S, F)$ is the sum of the Betti numbers of S with respect to any field F . The proof consists of two steps. First one expresses $\text{TAC}(S)$ as the integral of the number ν of critical points of the orthogonal projection of S on the directions of $\mathbb{R}P^{n-1}$

$$\text{TAC}(S) = \int_{\mathbb{R}P^{n-1}} \nu(S, u) \, du.$$

The second step is to apply the Morse inequalities to state that, for almost all $u \in \mathbb{R}P^{n-1}$,

$$\nu(S, u) \geq \sum_{i=0}^n \dim H_i(S, F). \quad (3.16)$$

The study of equality case in 3.15 led to the notion of *tight* immersions.

Definition 3.5.1. An immersion $i : S \rightarrow \mathbb{R}^n$ of a compact manifold in \mathbb{R}^n is called tight if for some field F

$$\text{TAC}(S) = \frac{O_{n-1}}{2} \beta(S, F).$$

It is easy to see (cf. [Kui97], p.35) that an immersion is tight if and only if the equality sign holds in (3.16) when the orthogonal projection onto u is a Morse function (non-degenerate critical points with different values). A less obvious characterization that is usually taken as a definition is the following.

Proposition 3.5.1. *Let $i : S \longrightarrow \mathbb{R}^n$ be an immersed submanifold. For every vector $v \in \mathbb{R}^n$ consider the closed half-space $H_v = \{z \in \mathbb{R}^n \mid \langle z, v \rangle \leq 1\}$ and the inclusion $j_v : i^{-1}(H_v) \rightarrow S$. The immersion i of S is tight if and only if there is some field F such that the homology morphisms $(j_v)_* : \check{H}_*(i^{-1}(H_v), F) \rightarrow \check{H}_*(S, F)$ induced by j_v are injective for every v .*

The proof can be found in [Kui97, p.35].

Remark. In this proposition, \check{H}_* stands for the Čech homology. For CW-complexs, it coincides with H_* , the singular homology. If X is a compact subset of a manifold or CW-complex then $\check{H}_*(X)$ is the inverse limit of $H_*(Y_n)$ where $Y_i \supset Y_{i+1} \supset \dots \supset X$ is sequence of open sets converging to X . This is the only fact about Čech homology we will need to know.

If $i : S \rightarrow \mathbb{R}^3$ is an immersed surface in euclidean space, the total absolute curvature $\text{TAC}(S)$ is the integral on S of the absolute value of the Gauss curvature. In this case, it is easy to prove that

$$\text{TAC}(S) = \int_S |K| dx \geq 2\pi(4 - \chi(S)). \quad (3.17)$$

The idea of the proof is as follows. Take \bar{S} the boundary of the convex hull of S and see that $\bar{S} \setminus S$ has total absolute curvature 0. Then by the Gauss-Bonnet theorem,

$$\int_S |K| = 2 \int_S K^+ - \int_S K \geq 2 \int_{\bar{S}} K - 2\pi\chi(S) = 8\pi - 2\pi\chi(S). \quad (3.18)$$

We will immediately see that (3.17) is a particular case of the Chern-Lashof inequality (3.15).

Let us recall the homology groups of a compact surface of the form $S = S^2 \#_g \mathbb{T}^2$ in the orientable case and of the form $S' = S^2 \#_g \mathbb{R}\mathbb{P}^2$ in the non-orientable case.

$$\begin{aligned} H_0(S, \mathbb{Z}) &= \mathbb{Z} & H_1(S, \mathbb{Z}) &= \mathbb{Z}^{2g} & H_2(S, \mathbb{Z}) &= \mathbb{Z} \\ H_0(S', \mathbb{Z}) &= \mathbb{Z} & H_1(S', \mathbb{Z}) &= \mathbb{Z}_2 \oplus \mathbb{Z}^{g-1} & H_2(S', \mathbb{Z}) &= 0. \end{aligned}$$

while with coefficients in \mathbb{Z}_2 they are

$$\begin{aligned} H_0(S, \mathbb{Z}_2) &= \mathbb{Z}_2 & H_1(S, \mathbb{Z}_2) &= \mathbb{Z}_2^{2g} & H_2(S, \mathbb{Z}_2) &= \mathbb{Z}_2. \\ H_0(S', \mathbb{Z}_2) &= \mathbb{Z}_2 & H_1(S', \mathbb{Z}_2) &= \mathbb{Z}_2^g & H_2(S', \mathbb{Z}_2) &= \mathbb{Z}_2. \end{aligned}$$

We see that $\chi(S) = 2 - 2g$, $\chi(S') = 2 - g$, $\beta(S, \mathbb{Z}_2) = 2 + 2g$ and $\beta(S', \mathbb{Z}_2) = 2 + g$. Observe that in all cases $4 - \chi(S) = \beta(S, \mathbb{Z}_2)$. Note also that $\beta(S, \mathbb{R}) = \beta(S, \mathbb{Z}) \leq \beta(S, \mathbb{Z}_2)$. Thus inequality (3.17) is just the Chern-Lashof inequality for the field \mathbb{Z}_2 . Thus a surface in \mathbb{R}^3 is tight when the equality sign holds in (3.17).

From (3.18) one can deduce that tightly immersed surfaces are characterized by the fact of having all the positive curvature points in the boundary of the convex hull.

Another characterization of tight surfaces in \mathbb{R}^3 is the so-called *two piece property*: a surface S immersed in \mathbb{R}^3 is tight if and only if every affine plane L divides it in two or less pieces; i.e. $i^{-1}(\mathbb{R}^3 \setminus L)$ does not have more than 2 connected components (cf.[Kui97]).

3.5.2 Surfaces in Hyperbolic 3-Space.

We start the study of total absolute curvature in hyperbolic space with surfaces in \mathbb{H}^3 . Let $i : S \rightarrow \mathbb{H}^3$ be an immersion of a closed surface (orientable or not). Its total absolute curvature is the integral on $i(S)$ of the absolute value of K , the Gauss curvature

$$\text{TAC}(S) := \int_S |K| dx.$$

Proposition 3.5.2. *If A is the area of $i(S)$ and \bar{A} is that of its convex envelope (boundary of its convex hull) then*

$$\text{TAC}(S) \geq 2\pi(4 - \chi(S)) + 2\bar{A} - A \quad (3.19)$$

and

$$\text{TAC}(S) \geq 4\pi + \bar{A}.$$

The second part already appeared in [LS00].

Proof. Set $K^+ = \max\{K, 0\}$ and $K^- = \max\{-K, 0\}$.

$$\begin{aligned} \int_S |K| dx &= \int_S K^+ dx + \int_S K^- dx = \\ &= 2 \int_S K^+ dx - \int_S K dx. \end{aligned}$$

By the Gauss-Bonnet formula in \mathbb{H}^3 ,

$$\int_S K dx = 2\pi\chi(S) + A. \quad (3.20)$$

On the other hand, if U is the relative interior of $S \cap \bar{S}$ in \bar{S} , it is clear that the support planes at points of $\bar{S} \setminus U$ have at least two contact points with S . Thus, they have a common segment with \bar{S} . By the Sard-Federer theorem (cf. [Fed69, 3.4.3]), this implies that the support planes of $\bar{S} \setminus U$ have null measure in $\gamma(\bar{S}) \subset \Lambda^n$, the set of support planes. Thus, the tangent planes in U have total measure and by proposition 3.4.6

$$4\pi + \bar{A} = \text{TAC}(\bar{S}) = \text{TAC}(U) = \int_U K.$$

Finally,

$$\int_S K^+ \geq \int_U K = 4\pi + \bar{A}. \quad (3.21)$$

From where the second inequality of the statement is deduced. The first inequality follows from (3.20) and (3.21). \square

From this proof is deduced that in (3.19) the equality sign holds if and only if **all** the positive curvature points of S stay in the convex envelope. It has been already said that this property characterizes tight surfaces in \mathbb{R}^3 . Therefore, even if it is not clear what should tight mean in hyperbolic geometry, a reasonable definition would be that a surface immersed in \mathbb{H}^3 is *tight* if one has equality in (3.19); equivalently if all the points with positive curvature belong to the convex envelope. Cecil and Ryan gave in [CR79] a different definition of tightness in \mathbb{H}^n which is more restrictive; but we will return to this later.

Is the term $2\bar{A} - A$ in (3.19) really necessary? This is a natural question. Some works express the hope that the Chern-Lashof inequality should hold without change in \mathbb{H}^n (cf. [Teu88, WS66]). This hope was refuted in [LS00] where examples of surfaces in \mathbb{H}^3 total absolute curvature below the bound of Chern-Lashof were constructed. More precisely, for those examples the equality sign in (3.19) holds and the term $2\bar{A} - A$ takes a negative value for them. Next we construct examples of the same type but with a lower genus.

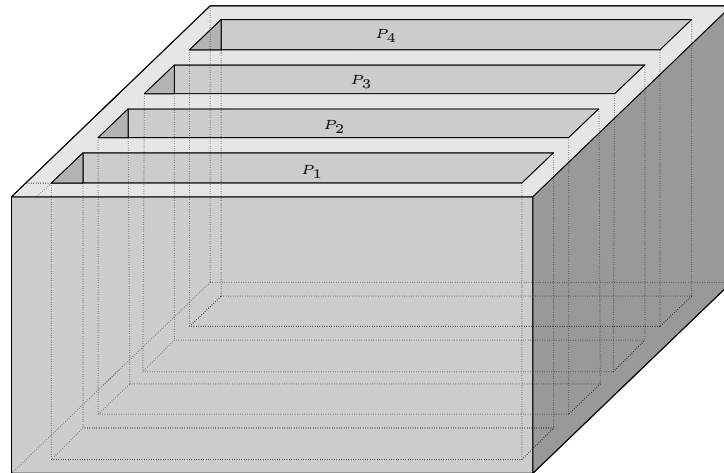

Figure 3.3: Polyhedral Surface of genus 4

Theorem 3.5.3. *For every $g > 1$ there is an orientable surface S in \mathbb{H}^3 with genus g and total absolute curvature below $2\pi(2 + 2g)$.*

Proof. We construct it almost explicitly in the projective model. Consider the orthohedron

$$P(a, b, c) = \{(x, y, z) \in \mathbb{R}^3 \mid |x| \leq a, |y| \leq b, |z| \leq c\}$$

for $0 < a, b, c$ such that $a^2 + b^2 + c^2 < 1$ (i.e. $P(a, b, c) \subset B(0, 1)$). Now for a small $\epsilon > 0$ draw g rectangles in the upper and lower faces of $P(a, b, c)$ at distance ϵ one from the other, as shown in figure 3.3. These rectangles determine g orthohedrons

P_1, \dots, P_g contained in $P(a, b, c)$. Then we consider the domain $P = P(a, b, c) - \cup_i P_i$ with polyhedral boundary. This boundary is a non-smooth topological surface orientable of genus g and it is tight in the euclidean sense. Since all its vertices are convex or of saddle type, one can apply the smoothenig procedure of [KP85] to get smooth tight surfaces (in the euclidean sense) S coinciding with ∂P except in a small neighborhood of the edges. Since S is tight in the euclidean sense, all its positive curvature points belong to its convex envelope \bar{S} . Thus, the total absolute curvature of S is

$$\text{TAC}(S) = 2\pi(2 + 2g) + 2\bar{A} - A$$

where \bar{A} and A are the respective areas of \bar{S} and S . We finish by showing that, choosing suitably a, b and c we can make $2\bar{A} - A$ be negative. Indeed, let a go to 0. Then, the areas of the sides of ∂P parallel to $x = 0$ converge all of them to the same value $B > 0$. The rest of sides of P have arbitrarily small areas so, since S is arbitrarily close to ∂P ,

$$\bar{A} \sim 2B \quad A \sim (2g + 2)B$$

and for $g > 1$ we have $2\bar{A} - A < 0$ if a is small enough. □

Some questions arise from these examples. The most general one is to find the greatest lower bound for the total absolute curvature between all the immersions in \mathbb{H}^3 of a given surface. This value exists, is greater than 4π and in the orientable case is lower than $2\pi(2 + 2g)$. It seems reasonable to expect this bound to be increasing with g but this it is not clear. Related to this, it is worthy to mention that for immersions included in a ball of radius ρ , one has the following bound (cf.[Teu88])

$$\text{TAC}(S) \geq \frac{O_{n-1}}{2} \frac{\beta(S)}{\cosh^{n-1} \rho}.$$

Another question is whether there are examples with genus 1 of the same kind as before. The answer is not. At the end of this chapter we will prove that a torus for which the equality sign in (3.19) holds has total absolute curvature greater than 8π . This suggests that this bound could be valid for any immersion of a torus.

Conjecture. For any immersed torus in \mathbb{H}^3 , the total absolute curvature is greater 8π .

We finish this discussion of the dimension 3 case with a proposition about the integral of the absolute value of **intrinsic** curvature. This is the curvature corresponding to the metric induced by the ambient. The Gauss equation states that the intrinsic curvature K_i and the extrinsic curvature K are related by $K = K_i + 1$.

Proposition 3.5.4. [LS00] *Let $i : S \rightarrow \mathbb{H}^3$ be an immersed surface in \mathbb{H}^3 . Then*

$$\int_S |K_i| \geq 2\pi(4 - \chi(S))$$

where K_i is the intrinsic curvature of M . The equality occurs only with topological sphere with non-negative K_i . That is, for convex hypersurfaces with Gauss curvature above 1.

Proof. Let \bar{S} be the convex envelope of S . Set $K_i^+ = \max\{K_i, 0\}$ and $K_i^- = -\min\{K_i, 0\}$. The arguments from proposition 3.5.2 give here

$$\int_S K_i^+ \geq \int_{S \cap \bar{S}} K_i^+ \geq \int_{S \cap \bar{S}} K_i = \int_{S \cap \bar{S}} K - 1 = 4\pi + A(\bar{S}) - A(S \cap \bar{S}) \geq 4\pi. \quad (3.22)$$

On the other hand,

$$\int_S K_i = \int_S K_i^+ - \int_S K_i^- = 2\pi\chi(S). \quad (3.23)$$

Comparing (3.22) and (3.23) we get the desired inequality. \square

3.5.3 Tight Immersions in Hyperbolic Space

The same ideas that led to the Cauchy-Crofton formula in the de Sitter sphere and to the Gauss-Bonnet theorem in hyperbolic space will also lead to an integral geometric formula for the total absolute curvature of tight immersions in \mathbb{H}^n .

Here the functions defined by the hyperplane bundles around $(n-2)$ -planes will play again an important role. Concretely, given L_{n-2} we define $h_L : \mathbb{H}^n \setminus L_{n-2} \rightarrow \mathbb{RP}^1 = \mathbb{S}^1$ sending every point $p \notin L_{n-2}$, to the hyperplane through p containing L_{n-2} . We identify naturally the bundle of hyperplanes around L_{n-2} to \mathbb{RP}^1 . We will not care about orientations since we will have interest only on the number of critical points of the functions h_L (restricted to submanifolds).

Let $i : S \rightarrow \mathbb{H}^n$ be an immersion. When L_{n-2} is disjoint from the convex hull of $i(S)$, the function $i \circ h$ will have its image contained in an interval of \mathbb{S}^1 . Thus we can think of this function as having values in \mathbb{R} . When it is a Morse function, the number of its critical points will be greater or equal than $\beta(S, F)$. Motivated by this we adopt the following definition of tightness in \mathbb{H}^n .

Definition 3.5.2. An immersion $i : S \rightarrow \mathbb{H}^n$ will be called *tight* when there is some field F such that for every $(n-2)$ -plane such that L_{n-2} does not intersect the convex hull of $i(S)$ and such that $h_L \circ i$ is a Morse function, the number of critical points of $h_L \circ i$ is $\beta(S, F)$.

There are also other equivalent definitions that are more similar to the euclidean one.

Proposition 3.5.5. *The following conditions are equivalent*

- i) *The immersion $i : S \rightarrow \mathbb{H}^n$ is tight*
- ii) *for every line L if the orthogonal projection $\pi_L \circ i : S \rightarrow L$ is a Morse function, the number of critical points is the Betti numbers' sum $\beta(S, F)$ for some field F ,*
- iii) *for every closed half-space H bounded by a geodesic hyperplane, the inclusion $j : i^{-1}(H) \rightarrow S$ induces a homology monomorphism $j_* : \check{H}_*(i^{-1}(H), F) \rightarrow \check{H}_*(S, F)$,*

iv) the inclusion is tight in the euclidean sense when taking the projective model of \mathbb{H}^n .

Proof. First of all note that condition *iv)* is invariant under isometries of projective model since euclidean tightness is invariant under projectivities not sending the points of the submanifold to infinity. The same fact shows that *ii)* is equivalent to *iv)*. Indeed, it suffices to move L to contain the origin of the model. Then the orthogonal projections onto L appear as euclidean orthogonal projections. To see that *iv)* implies *i)* send some hyperplane L_{n-1} disjoint to $i(S)$ and containing L_{n-2} to infinity. Then the function h_L becomes an orthogonal projection onto a direction $u \in \mathbb{R}\mathbb{P}^n$ and thus must have $\beta(S, F)$ critical points. Note also that for almost every L_{n-2} contained in a hyperplane L_{n-1} disjoint from $i(S)$, $h_L \circ i$ is a Morse function. Indeed, as a consequence of the Sard theorem, for almost all $u \in \mathbb{R}\mathbb{P}^n$ the orthogonal projection is a Morse function.

To show that *i)* implies *iii)* let us remain in the projective model and let H be a closed half-space bounded by a hyperplane. Take some hyperplane L_{n-1} orthogonal to ∂H and disjoint from $i(S)$. By the final remark of the last paragraph, there is some sequence of half-spaces H_i such that ∂H_i is transverse to $i(S)$, $i^{-1}(H_i) \supset i^{-1}(H_{i+1})$ with $H = \bigcap H_i$, and such that for $L = \partial H_i \cap L_{n-1}$ the function $h_L \circ i$ is of Morse. By hypothesis $h_L \circ i$ has $\beta(S)$ critical points. The standard arguments from Morse theory (cf. [Kui97], p.35) prove that $i^{-1}(H_i) = (h_L \circ i)^{-1}((-\infty, 0]) \subset S$ induces a homology monomorphism. We have

$$i^{-1}H \subset \dots \subset i^{-1}(H_2) \subset i^{-1}(H_1) \subset S$$

and at each stage we have a homology induced monomorphism. Since $H_*(S)$ has finite dimension, the induced homology sequence must stabilize and we have that $i^{-1}(H) \subset S$ induces an injective homology morphism.

Finally by proposition 3.5.1 it is clear that *iii)* implies *iv)* since geodesic hyperplanes in the projective model are affine hyperplanes. \square

Definition 3.5.2 is less restrictive than that of Cecil and Ryan in [CR79] for tightness in \mathbb{H}^n . Indeed, their condition is as follows. Given an oriented hyperplane L_{n-1} , consider the signed distance function d_L to L_{n-1} . Given an immersion $i : S \rightarrow \mathbb{H}^n$ and a value $a \in \mathbb{R}$ consider the closed $S_a = (d_L \circ i)^{-1}((-\infty, a])$ of S . The immersion i is tight in the sense of Cecil and Ryan if for every L_{n-1} and every $a \in \mathbb{R}$, the inclusion $j : S_a \rightarrow S$ induces a homology monomorphism $j_* : \check{H}_*(S_a, F) \rightarrow \check{H}_*(S, F)$. Note that we also impose the same condition but only for $a = 0$.

To check that the definition 3.5.2 is really less restrictive than that of [CR79] it is enough to note that the boundary of convex domain is tight according to our definition but not always according to Cecil and Ryan.

One could adopt the following definition that we are not going to use. An immersion is λ -geodesically tight if it is tight with respect to equidistant hypersurfaces of normal curvature below λ (cf. section 1.1.1). More concretely, i is λ -geodesically tight if $j_* : H(S_a, F) \rightarrow H(S, F)$ is a monomorphism for every a such that $|\tanh a| \leq \lambda$. This way, the immersions of 3.5.2 would be 0-tight and those of [CR79] would be 1-tight. Besides, a topological sphere would be λ -tight if and only if it were λ -convex (cf. definition 1.1.2).

Definition 3.5.2 is the less restrictive way to generalize the euclidean notion of tightness. Anyway, in the subsequent statements the tightness condition appears as a hypothesis. Therefore, these results would also hold with a more restrictive notion of tightness, as that of [CR79].

Before going into the details let us state the main result. Given an immersion $i : S \rightarrow \mathbb{H}^n$ of a compact manifold S its total absolute curvature is

$$\text{TAC}(S) = \frac{1}{2} \int_{N(S)} |K(x, \mathbf{n})| d\mathbf{n} dx.$$

We will prove that if i is tight (with respect to some field F), then

$$\int_{\mathcal{L}_{n-2}} (\beta(S, F) - \nu(L_{n-2}, i(S))) dL_{n-2} = \frac{O_{n-2}}{n-1} (\text{TAC}(S) - \frac{O_{n-1}}{2} \beta(S, F))$$

where $\nu(L_{n-2}, i(S))$ is the number of critical points of the function $h_L \circ i$ (or the number of contacts with $i(S)$ of the bundle of hyperplanes around L_{n-2}). Note that the definition of tightness warrants the integrand to vanish for every $(n-2)$ -plane disjoint from the convex hull of $i(S)$.

We start with the following lemma which is on tight immersions in euclidian space but, in virtue of *iv*) in proposition 3.5.5 and of proposition 1.2.3, can also be used for tight immersions in \mathbb{H}^n .

Lemma 3.5.6. *Let $i : S \rightarrow \mathbb{R}^n$ be a tight immersion of a hypersurface. Consider a generic $(n-2)$ -plane L and the bundle $L(t) = L + tv$ for every $t \in \mathbb{R}$ and some vector v orthogonal to L . If $\nu(L, i(S))$ is the number of critical points of $h_L \circ i$, then for almost all $t_0 \in \mathbb{R}$*

$$\nu(L(t_0), i(S)) - \nu(L, i(S)) = -2 \sum_{\substack{L(t) \subset \text{di}T_x S \\ 0 \leq t \leq t_0}} \text{sgn}K_x \text{sgn}K_x(L)$$

where K_x denotes the curvature of S with respect to the normal \mathbf{n} that makes $\langle v, \mathbf{n} \rangle > 0$ and $K_x(L)$ is the normal curvature normal in the direction of L also with respect to \mathbf{n} .

Proof. Take the vectorial 2-plane h orthogonal to L , and consider orthogonal projection π_h onto h . Consider the set $\Gamma_h \subset S$ of critical points of the projection $p_h = \pi_h \circ i : S \rightarrow h$ (figure 3.4). For generic h , Γ_h is a smooth curve (cf. [Lan97, LS82]). Thus the image $\gamma_h = p_h(\Gamma_h)$ is a smooth curve except in a finite number of pints. In particular, for almost every direction $u \in \mathbb{P}(h)$, the projectivization of h , the orthogonal projection of S onto u is a Morse function. Also, the tangent hyperplanes of S containing a $L + tv$ are tangent in points of Γ_h . Thus, such hyperplanes correspond, when intersected with h , to lines tangent to γ_h and passing by $p + tv$ where $p = L \cap h$. Besides, for generic h the singular points of γ_h are cusps. Indeed, since the tangent plane to S in the points of Γ_h moves continuously, if $p \in \gamma_h$ had two tangent lines one would have a whole interval of Γ_h projecting onto p . But this can be clearly avoided for generic h .

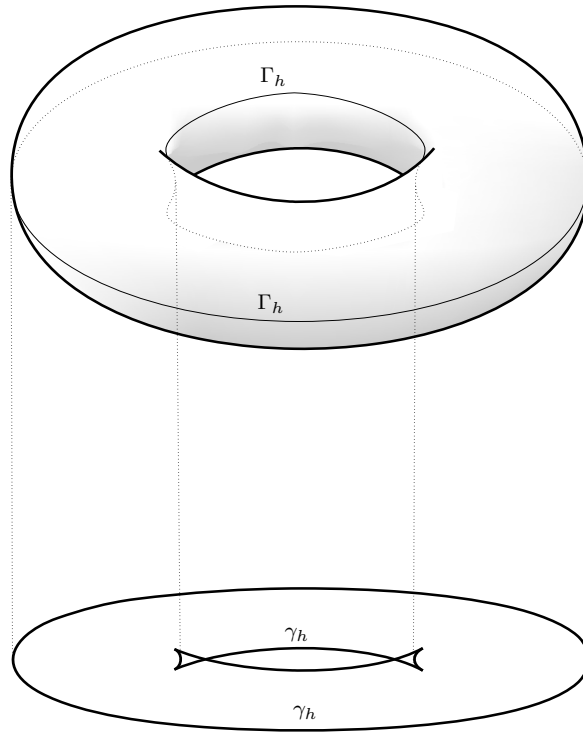

Figure 3.4: Polar curves

Let $y(s)$ be a length parametrization of γ_h , smooth except in a finite number of points where y' suddenly changes its sign. Consider the intersection point of the tangent line at $y(s)$ with line $p + \langle v \rangle$; that is $z(s) = (y(s) + \langle y'(s) \rangle) \cap (p + \langle v \rangle)$ (figure 3.5) which is continuous as long as y' and v are not parallel. For certain $f(s)$ and $g(s)$,

$$y(s) + g(s)y'(s) = p + f(s)v \tag{3.24}$$

Taking derivatives at a smooth point $y(s)$, one gets

$$(1 + g'(s))y'(s) + g(s)k(s)n(s) = f'(s)v$$

where n is the normal vector given by the orientation and k is the curvature of γ_h . Multiplying by n ,

$$g(s)k(s) = f'(s)\langle v, n(s) \rangle \tag{3.25}$$

Next we prove that when the immersion of S is tight the curvature k has constant sign on every closed curve of γ_h . The curvature k of γ_h could change its sign in an inflexion point, or in a singularity or when crossing an interval of curvature 0. We reduce ourselves to the first case since the others are almost identical. Let then, $y(s_0)$ be an inflexion point where k changes its sign. Figure 3.6 shows a curve with inflection

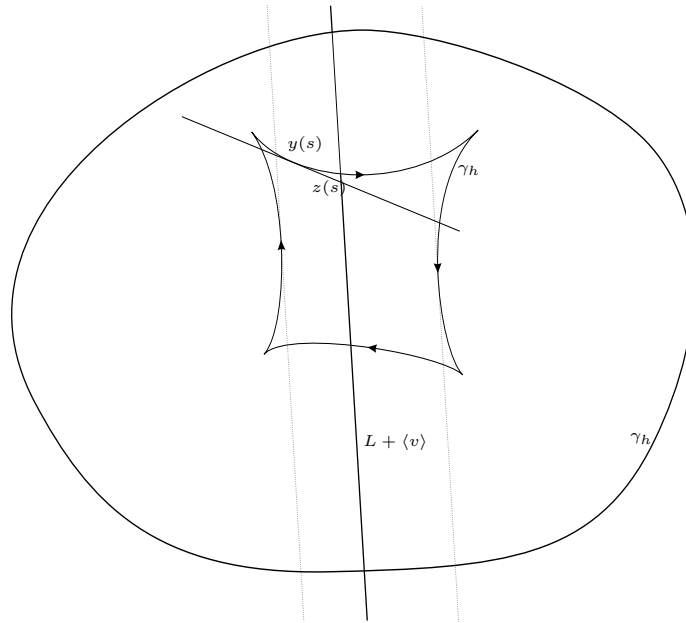

Figure 3.5: Curves $y(s)$ and $z(s)$

points such that at every point far enough the number of concurrent tangent lines is constant. To discard this possibility, we slightly modify immersion i . First modify the curve γ_h in a neighbourhood of $y(s_0)$ in the following way (figure 3.6). One can locally think of γ_h as a function $a(x)$ with $a'(0) = a''(0) = 0$ and $a(x) > 0$ for small $x > 0$. Take a slope $\lambda > 0$ also small and consider the line $b(x) = \lambda x$. Finally consider the function

$$\rho(x) = \begin{cases} \frac{1}{e^{x+\epsilon}} - \frac{1}{x-\epsilon} & -\epsilon < x < \epsilon \\ 0 & |x| \geq \epsilon \end{cases}$$

which is C^∞ and has a bell shape. Now construct

$$c(x) = (1 - \rho(x))a(x) + \rho(x)b(x).$$

One can easily check that for small enough λ , c has one only inflexion at the origin with derivative equal to λ . Replacing the graphic $a(x)$ by that of $c(x)$ in γ_h we get a new smooth curve. Now we can construct a diffeomorphism $\Phi : h \rightarrow h$ being the identity outside a neighborhood of $y(s_0)$, and modifying γ_h in the way we just described. Now extend Φ trivially to the diffeomorphism $\Psi = \Phi \times \text{id}$ of \mathbb{R}^n . The composition $i' = \Psi \circ i : S \rightarrow \mathbb{R}^n$ is a new immersion of S that no longer has to be tight. The new polar curve γ_h of S is the image through Φ of the ancient γ_h . Consider the interval $I \subset \mathbb{P}(h)$ between $y'(s_0)$ and $d\Phi(y'(s_0))$. For every direction $u \in I$, the orthogonal projection p_u of γ_h (and thus that of $i'(S)$) in u^\perp has less than $\beta(S, F)$ critical points. But for almost all these directions u , the projection $p_u \circ i$ is a Morse function. Since

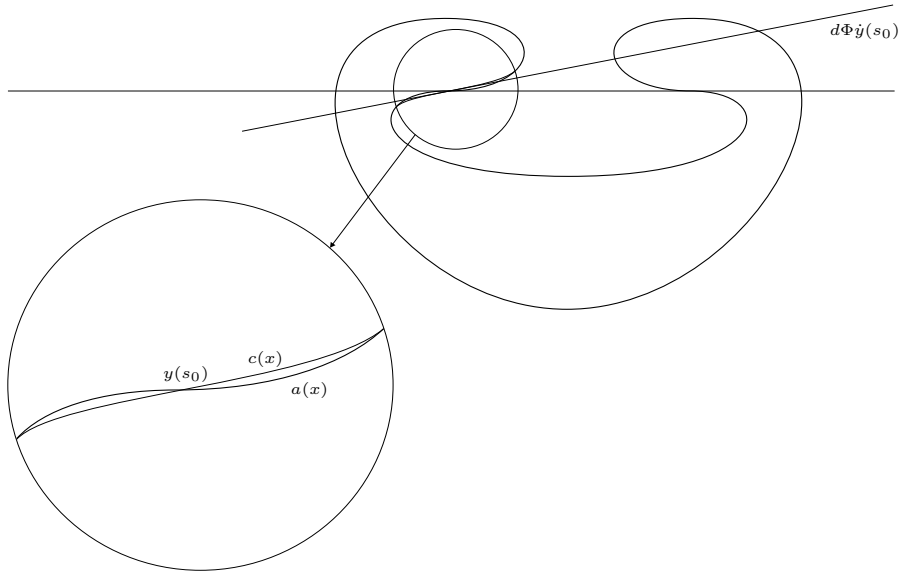

Figure 3.6: The case to refute

i has not been modified near the critical points of $p_u \circ i'$, for almost every u in I , the projection $p_u \circ i'$ is also a Morse function. But this contradicts the fact that it has less than $\beta(S, F)$ critical points!

Once we have seen that the curvature k of γ_h does not change its sign (even if it can vanish) on every closed curve, take again the original $(n - 2)$ -plane L and vector v . Geometrically it is clear that when $\langle n, v \rangle$ changes its sign, g also changes its sign (passing through infinity). By equation (3.25), if f' changes its sign in a regular point $y(s_0)$ then $g(s)$ also changes its sign at $s = s_0$. On the other hand, when crossing a singularity, $g(s)$ and $n(s)$ suddenly change its sign, and by l'equation (3.25) we see that f' does not change its sign at these points.

We deduce that f' changes its sign only where g vanishes. Thus, $f(s)$ is monotone in the intervals where $g(s) \neq 0$. That is, as long as $y(s)$ does not cross the line $l = p + \langle v \rangle$. From equation (3.24) we deduce that in the intersection points (where $y(s_0) = z(s_0)$) one has $g'(s_0) = -1$. Taking derivatives again (3.24), in such a point s_0 we have

$$g''y' - kn = f''v \implies -k = f''\langle v, n \rangle.$$

So, locally the curves $y(s)$ and $z(s)$ are in opposite half-spaces with respect to the tangent line at $y(s_0)$.

We have shown that the number of pre-images through z of the points of l is constant on the intervals defined by the intersection points with γ_h . If $y(s)$ is one of these points, for small enough ϵ

$$\#z^{-1}(z(s) + \epsilon v) - \#z^{-1}(z(s) - \epsilon v) = -2\text{sgn}\langle v, n \rangle \text{sgn}k$$

where k is the curvature of y .

To finish we apply d'Ocagne's theorem (cf. [LS82]) which states that the curvature of S is product of the curvature of γ_h by the normal curvature of S in the direction $(h)^\perp$. In particular,

$$\operatorname{sgn}k = \operatorname{sgn}K \operatorname{sgn}K(h)^\perp.$$

□

After such a complicated proof the rest is mechanic.

Proposition 3.5.7. *Let $i : S \rightarrow \mathbb{H}^n$ be a tight immersion of a hypersurface in the projective model of \mathbb{H}^n . Consider the family of immersions $i_t = h(1/t) \circ i$ where $h(\lambda)$ is the euclidean homothety of ratio λ fixing the origin, and $t > 1$. Then for $t' > t > 1$*

$$\lim_{t' \rightarrow t} \frac{1}{t' - t} \int_{\mathcal{L}_{n-2}} (\nu(L_{n-2}, i_{t'}(S)) - \nu(L_{n-2}, i_t(S))) dL_{n-2} = -\frac{O_{n-2}}{n-1} \frac{d}{dt} \operatorname{TAC}(i_t(S)).$$

Proof. Fix a generic L_{n-2} . After rescaling the situation is equivalent to have $i(S)$ fixed and L_{n-2} moving as in lemma 3.5.6. Thus, for any unit normal n on $i(S_t)$

$$\nu(L_{n-2}, i_{t'}(S)) - \nu(L_{n-2}, i_t(S)) = -2 \sum_{\substack{L_{n-2} \subset \operatorname{di}_s T_x S \\ t \leq s \leq t'}} \operatorname{sgn}\phi \operatorname{sgn}K_s \operatorname{sgn}K_s(L_{n-2}).$$

where $\phi = \langle \partial i / \partial t, n \rangle$. From here, tracking the proof of theorem 3.3.2 one gets that

$$\lim_{t' \rightarrow t} \frac{1}{t' - t} \int_{\mathcal{L}_{n-2}} (\nu(L_{n-2}, i_{t'}(S)) - \nu(L_{n-2}, i_t(S))) dL_{n-2} = O_{n-2} \int_{S_t} \phi \sigma_{n-2} \operatorname{sgn}K_t dx$$

being σ_{n-2} the $(n-2)$ -th mean curvature of S_t . On the other hand, take $U^+ = \{x \in S \mid K_x(S_t) > 0\}$ and $U^- = \{x \in S \mid K_x(S_t) < 0\}$. If $\gamma_t : S \rightarrow \mathcal{L}_{n-1}$ is the Gauss map of $i_t(S)$, in the proof of lemma 3.4.1 we have seen that

$$\frac{d}{dt} \int_{U^+} K_t(x) dx = -(n-1) \int_{\gamma_t(U^+)} \phi \tilde{\sigma}_1 d\tilde{x} \quad \frac{d}{dt} \int_{U^-} K_t(x) dx = -(n-1) \int_{\gamma_t(U^-)} \phi \tilde{\sigma}_1 d\tilde{x}$$

being $\tilde{\sigma}_1$ the mean curvature and $d\tilde{x}$ the volume element of $\gamma_t(S)$. Subtracting we get that

$$\frac{d}{dt} \int_S K_t dx = -(n-1) \int_{\gamma_t(S)} \phi \tilde{\sigma}_1 \operatorname{sgn}K_t d\tilde{x}$$

and by corollary 2.3.9 we have finished. □

Theorem 3.5.8. *If $i : S \rightarrow \mathbb{H}^n$ is a tight immersion of any codimension of a compact boundaryless manifold S , then the total absolute curvature is given by*

$$\operatorname{TAC}(i(S)) = \frac{O_{n-1}}{2} \beta(S) + \frac{n-1}{O_{n-2}} \int_{\mathcal{L}_{n-2}} (\beta(S) - \nu(L_{n-2}, i(S))) dL_{n-2} \quad (3.26)$$

where β is the sum of the Betti numbers.

Proof. Start with the case of codimension 1. Suppose the immersion is in the projective model. Consider, for $1 \leq t < \infty$ the family i_t of immersions of the previous proposition. The image $i_t(S)$ is included in a ball of radius $1/t$; that is, arbitrarily small. Integrating the formula from the previous proposition we have, for every $t > 1$,

$$\text{TAC}(i(S)) - \text{TAC}(i_t(S)) = \frac{n-1}{O_{n-2}} \int_{\mathcal{L}_{n-2}} (\nu(L_{n-2}, i(S)) - \nu(L_{n-2}, i_t(S))) dL_{n-2}$$

Since the geometry of small balls of \mathbb{H}^n is more and more similar to euclidian and i_t is tight at any moment, it is clear that

$$\lim_{t \rightarrow \infty} \text{TAC}(i_t(S)) = \frac{O_{n-1}}{2} \beta(S).$$

On the other hand, for every L_{n-2} not intersecting the ball of radius $1/t$, we have $\nu(L_{n-2}, i_t(S)) = \beta(S)$.

Let now $i : S \subset \mathbb{H}^n \subset \mathbb{R}^n$ be an immersion of codimension bigger than 1 in the projective model. One would like to take its tube which is a hypersurface. But this tube with small enough radius is tight if and only if the Betti numbers' sum of the unit normal bundle is twice that $\beta(S)$ (cf. [BK97]). A result from [BK97] states that this is the case when S is contained in some hyperplane. Thus, we take a linear embedding $j : \mathbb{H}^n \rightarrow \mathbb{H}^{n+1}$ between projective models and we consider the euclidean tube T_ϵ of radius ϵ around $(j \circ i)(S)$. Then we apply the previous case to T_ϵ , and make ϵ tend to 0. Now it is not difficult to check that

$$\lim_{\epsilon \rightarrow 0} \text{TAC}(T_\epsilon) = 2\text{TAC}((j \circ i)(S)) = \frac{2O_n}{O_{n-1}} \text{TAC}(i(S)).$$

On the other hand, the integrand in (3.26) is null for all the planes not intersecting $j(\mathbb{H}^n)$ (or the convex hull of $j \circ i(S)$). The rest of the $(n-1)$ -planes are given by an $(n-2)$ -plane in $j(\mathbb{H}^n)$ and some vector. Thus, since for almost all $(n-2)$ -planes L there is some ϵ such that $\nu(T_r, L) \equiv \nu(i(S), L \cap j(\mathbb{H}^n))$ for every $r < \epsilon$, we have

$$\begin{aligned} \frac{2O_n}{O_{n-1}} \text{TAC}(i(S)) &= \frac{O_n}{2} \beta(T_r(j \circ i(S))) - \\ &- \frac{n}{O_{n-1}} \frac{O_1}{n} \cdot \int_{\mathcal{L}_{[n](n-2)}} (\beta(T_r(j \circ i(S))) - 2\nu(i(S), L \cap j(\mathbb{H}^n))) dL_{n-2}. \end{aligned}$$

□

Now we apply the preceding results to the space of dimension 3. We will get again that a tight surface in \mathbb{H}^3 fulfills the equality in (3.17). Let $i : S \rightarrow \mathbb{H}^3$ be a tightly immersed surface in \mathbb{H}^3 . We have

$$\int_{\mathcal{L}} (4 - \chi(S) - \nu(i, L)) dL = \pi(\text{TAC}(S) - 2\pi(4 - \chi(S))).$$

Integration can be restricted to lines intersecting the convex hull of $i(S)$. For each line L consider the field $X(p) = d(p, L) \cdot \nabla h_L(p)$, tangent to the rotation around L_{n-2} , which

is smooth over all \mathbb{H}^n . Let Y be the orthogonal projection of X on the tangent space of $i(S)$. The Poincaré formula states that $\chi(S) = i_+ - i_-$ where i_+ is the number of singularities of Y with positive index and i_- is that of the ones with negative index. In our case, i_+ is the number of intersection points $L \cap i(S)$ plus the number of planes containing L and tangent to $i(S)$ in points of positive curvature. But if i is tight, all the points with positive curvature belong to \bar{S} , the boundary of the convex hull. Therefore, if L cuts \bar{S} we have $i_+ = \#(L \cap i(S))$ and $i_- = \nu(i, L) = \#(L \cap i(S)) - \chi(S)$. Thus

$$\int_{\{L \cap \bar{S} \neq \emptyset\}} (4 - \#(L \cap i(S))) dL = \pi(\text{TAC}(S) - 2\pi(4 - \chi(S))).$$

And applying the Cauchy-Crofton formula we find again

$$\text{TAC}(S) = 2\pi(4 - \chi(S)) + 2\bar{A} - A$$

where A and \bar{A} are the areas of $i(S)$ and the boundary of \bar{S} , respectively.

Again in higher dimensions, combining theorem 3.5.8 and the ideas of lemma 3.5.6 we get the following proposition which for $n = 3$ is a particular case of the conjecture in page 74.

Theorem 3.5.9. *The total absolute curvature of a **tight** immersion of the torus T^2 in \mathbb{H}^n is strictly bigger than 8π .*

Proof. Let $i : T^2 \rightarrow \mathbb{H}^n$ be a tight immersion of the torus T^2 in the projective model. Consider L a generic $(n - 2)$ -plane. We will see that $\nu(i, L) \leq 4$. Take a 2-plane h orthogonal to L . Consider the curve γ_h of critical values of the orthogonal projection of T^2 onto h . Since i is tight we know that for almost every direction $u \in \mathbb{P}(h) \equiv \mathbb{RP}^1$ there are exactly 4 lines in h , with direction u and tangent to γ_h .

Thus, γ_h will be made of two closed curves C_1 and C_2 , the most exterior of which (C_1) is convex since it corresponds to the critical points belonging to the convex hull of $i(T^2)$.

We have to show that through $p = L \cap h$ there are no more than 4 tangent lines to γ_h . Through almost every p that is exterior to C_1 there are exactly 4 tangent lines. Suppose a point p interior to C_1 but not to C_2 . One can move p along a half-line crossing γ_h in only one point, which will be of C_1 . When crossing this point, since C_2 is convex, by lemma 3.5.6 we know that p will gain 2 tangent lines. Thus, through points between C_1 and C_2 there are 2 tangent lines. Finally suppose p also interior to C_2 . In this case, C_2 turns exactly once around p . Indeed, if it turned twice or more, for every direction there would be more than two lines tangent to C_1 with the given direction. Thus, p can be joint to a point p' as in the previous case through a polygonal line crossing C_2 only in one point. When crossing C_2 , the point p can gain or loose 2 tangent lines. Since through p' there are 2 tangent lines, through p there can be 4 or none. In any case we have seen the maximal number of concurrent tangent lines of γ_h to be 4. Finally, the inequality is strict since there is always some generic L for which ν is 2. \square

Chapter 4

Inequalities between mean curvature integrals

4.1 Introduction

In euclidean space, the Minkowski inequalities are well-known. They apply to convex bodies and involve its Quermassintegrale and thus, the mean curvature integrals. To be precise, for a convex body $Q \subset \mathbb{H}^n$, the Minkowski inequalities are

$$M_i(\partial K)^j \geq cM_j(\partial K)^i \quad i > j$$

for certain constants c . For instance, in \mathbb{R}^3 they are

$$M_0^2 \geq 36\pi V^2, \quad M_1^3 \geq 48\pi^2 V, \quad M_1^2 \geq 4\pi M_0 \quad \text{and} \quad M_0^2 \geq 3VM_1.$$

Let us take a look at the powers. Its is natural that they appear since M_i is a magnitude of *order* $n - i - 1$. In other words, if tQ is the homothetic image of Q with ratio t , then $M_i(t\partial Q) = t^{n-i-1}M_i(Q)$. Therefore, its is nonsense to compare M_i and M_j without taking the proper powers. Even more clear, for a radius R ball, the quotient $M_i/M_j = R^{i-j}$ (cf. (1.10)) can take any positive value. Then, one can not have any inequality in the style $M_i > cM_j$.

Its is worthy to recall here the following remark of Santaló (cf. [San70]). Any sequence of convex sets Q_r expanding to fill the whole \mathbb{R}^n fulfills

$$\lim_{r \rightarrow \infty} \frac{M_i(\partial Q_r)}{M_j(\partial Q_r)} = 0 \quad i < j. \quad (4.1)$$

In hyperbolic geometry there is no such notion of ‘magnitude order’. Firstly, homotheties do no exist in hyperbolic space. Secondly, in the balls example one has $M_i/M_j = \tanh^{j-i} R$ which for $j < i$ is strictly bigger than 1. Thus, it is not so hopeless to try to compare M_i and M_j without taking any power. We should also consider the problem of comparing the Quermassintegrale W_i of a convex body in \mathbb{H}^n since they

also generalize the mean curvature integrals of euclidean convex sets. For instance, it is known that for any domain $Q \subset \mathbb{H}^n$

$$\text{vol}(Q)(n-1) < \text{vol}(\partial Q). \quad (4.2)$$

In fact, a result by Yau (cf. [Yau75]) states the preceding inequality in any simply connected manifold with sectional curvature $K \leq -1$.

In this chapter we prove inequalities in the style

$$M_i(\partial Q) > cM_j(\partial Q) \quad i > j$$

where $Q \subset \mathbb{H}^n$ is any convex domain. We will use integral geometry in an essential way, specially the formula (3.14). The plan starts by finding inequalities between Quermassintegrale. This is done by means of an elementary but quite original and effective geometric argument. From here, thanks to the simplicity of expression (3.14), one gets inequalities between the mean curvature integrals.

Note that if the radius R of a ball in \mathbb{H}^n grows to infinity, then the quotient $\text{vol}(B(R))/\text{vol}(\partial B(R))$ approaches the bound $n-1$ given by (4.2). In fact, Santaló and Yañez proved in [SY72] that the same happens with any sequence of h -convex domain expanding to fill \mathbb{H}^2 . There (and after in [San80]) it was conjectured that the same was true for any sequence of (geodesically) convex domains. After, Gallego and Reventós (cf. [GR85]) proved that this was false by constructing sequences of regular polygons expanding to fill \mathbb{H}^2 and for which the quotient between area and perimeter approaches any value between 1 and infinity. At the end of this chapter we will construct examples generalizing this fact to higher dimensions.

Concerning sequences of h -convex bodies, Borisenko and Miquel generalized the result of Santaló and Yañez by proving that

$$\lim_{r \rightarrow \infty} \frac{\text{vol}(Q_r)}{\text{vol}(\partial Q_r)} = \frac{1}{n-1} \quad \text{and} \quad \lim_{r \rightarrow \infty} \frac{M_i(\partial Q_r)}{M_j(\partial Q_r)} = 1$$

for any sequence (Q_r) of h -convex domains expanding to fill hyperbolic space. Such a controlled behavior of h -convex domains with respect to that of general convex domains motivated the study of the same questions for sequences (Q_r) of λ -convex domains for $0 \leq \lambda \leq 1$ expanding to fill \mathbb{H}^n . To be precise it was proved in [BV97] that

$$\frac{1}{n-1} \leq \lim \frac{\text{vol}(Q_n)}{\text{vol}(\partial Q_n)} \leq \frac{\lambda}{n-1} \quad (4.3)$$

For dimension 2, examples are given in [GR99] of sequences attaining all the limit values allowed by the previous inequality. At the end of this chapter we construct examples of sequences showing the same in higher dimensions.

In connection to these problems, it has also been studied the quotient between diameter and perimeter of sequences of convex domains expanding to fill \mathbb{H}^2 (cf. [GS01]). To be precise it is found that this limit is conditioned by the limit of the quotient between area and perimeter as well as by the λ -convexity assumption.

For completeness, we mention that in the latest times these results have been generalized to manifolds with negative bounded sectional curvature. A domain Q in such a manifold is called to be λ -convex if its boundary has normal curvature greater than $\lambda > 0$ at any point in any direction. In a simply connected manifold with sectional curvature bounded by $-k_1^2 \leq K \leq k_2^2$, it was proved in [BGR01] that for any sequence Q_r of λ -convex sets expanding to fill the manifold one has

$$\frac{\lambda}{k_2^2(n-1)} \leq \lim_r \frac{\text{vol}(Q_r)}{\text{vol}(\partial Q_r)} \leq \frac{1}{k_1^2(n-1)} \quad (4.4)$$

or also ([BM02])

$$\frac{\lambda^{i-j}}{k_2^2} \leq \frac{M_i(\partial Q)}{M_j(\partial Q)} \leq \frac{\lambda^{j-i}}{k_1^2}. \quad (4.5)$$

Unfortunately, our methods, so linked to integral geometry, can hardly be used in such non-homogeneous manifolds.

4.2 Inequalities between Quermassintegrale

In this section we prove that for any convex domain Q in \mathbb{H}^n ,

$$W_r(Q) < c_{n,r,j} W_{r+j}(Q)$$

for certain constants $c_{n,r,j}$ depending on the dimensions.

We start proving similar inequalities for convex domains in \mathbb{S}^n which will be useful after. Recall that the space of geodesic r -planes in \mathbb{S}^n is just the grassmannian $G(r+1, n+1)$ of linear $(r+1)$ -planes of \mathbb{R}^{n+1} .

Proposition 4.2.1. *Let Q be a convex set in \mathbb{S}^n . Then, for $s = 1, \dots, n-1$ and $r = 0, \dots, n-s-1$*

$$\int_{G(r+1, n+1)} \chi(L_r \cap Q) \, dL_r \leq \frac{O_{r+s} \cdots O_{r+1}}{O_{n-r-1} \cdots O_{n-r-s}} \int_{G(r+s+1, n+1)} \chi(L_{r+s} \cap Q) \, dL_r$$

and equality holds only when Q is a hemisphere of \mathbb{S}^n .

Proof. Denote $G(r+1, r+s+1, n+1)$ the flag space consisting of pairs $L_r \subset L_{r+s}$ of geodesic planes of \mathbb{S}^n . Recall (cf.(2.5)) that in this space

$$dL_{(r+s)[r]} dL_r = dL_{[r+s]r} dL_{r+s}$$

where $dL_{[r+s]r}$ is the measure on the grassmannian of r -planes contained in L_{r+s} and $dL_{(r+s)[r]}$ is the measure of $(r+s)$ -planes containing L_r .

Note that, for any flag of $G(r, r + s, n + 1)$, if the r -dimensional plane meets Q , then so does the $(r + s)$ -dimensional plane. Thus

$$\begin{aligned} \text{vol}(G(r + 1, r + s + 1)) \int_{G(r+s+1, n+1)} \chi(L_{r+s} \cap Q) dL_{r+s} &= \\ &= \int_{G(r+1, r+s+1, n+1)} \chi(L_{r+s} \cap Q) dL_{[r+s]r} dL_{r+s} \geq \\ &\geq \int_{G(r+1, r+s+1, n+1)} \chi(L_r \cap Q) dL_{(r+s)[r]} dL_r = \\ &= \text{vol}(G(s, n + 1 - r)) \int_{G(r+1, n+1)} \chi(L_r \cap Q) dL_r. \end{aligned}$$

To finish recall that

$$\text{vol}(G(r, n)) = \frac{O_{n-1} \cdots O_{n-r}}{O_{r-1} \cdots O_0}.$$

□

Recalling the definition 2.2.1 we get the following corollary.

Corollary 4.2.2. *If $Q \subset \mathbb{S}^n$ is convex then*

$$W_r(Q) \leq \frac{(n - r) O_{r+s} O_{n-r-s-1}}{(n - r - s) O_{n-r-1} O_r} W_{r+s}(Q).$$

and equality holds only for hemispheres.

Remark. This result holds only for convex sets. For general domains there are counterexamples. For instance, for \mathbb{S}^2 minus a small neighborhood of the north pole one has $W_1 \sim 0$ and $W_0 \sim 4\pi$.

Using these results, we prove the analogues in hyperbolic space.

Proposition 4.2.3. *Let Q be a convex domain in \mathbb{H}^n contained in a radius R ball. Then, for $s = 1, \dots, n - 1$ and $r = 0, \dots, n - s - 1$*

$$\int_{\mathcal{L}_r} \chi(L_r \cap Q) dL_r < \tanh^s(R) \frac{O_{r+s-1} \cdots O_r}{O_{n-r-2} \cdots O_{n-r-s-1}} \int_{\mathcal{L}_{r+s}} \chi(L_{r+s} \cap Q) dL_{r+s}.$$

Proof. Choose an origin $O \in Q$. We denote by P_r the r -dimensional linear subspaces of \mathbb{R}^n . Using expression (2.4) for the measure of r -planes,

$$\int_{\mathcal{L}_r} \chi(L_r \cap Q) dL_r = \int_{G(n-r, n)} \int_{P_{n-r}} \chi(L_r \cap Q) \cosh^r \rho dx dP_{n-r}$$

where dx is the volume element of every P_{n-r} and L_r is the r -plane orthogonal to P_{n-r} at the point x . About dP_{n-r} , it is the natural invariant measure in $G(n - r, n)$, leading

to the measure of $(n - r - 1)$ -planes in \mathbb{S}^{n-1} . Let us write dx in polar coordinates. In other words, let x be given by its distance to O and by the line joining them. Then

$$\int_{\mathcal{L}_r} \chi(L_r \cap Q) dL_r = \int_{G(n-r,n)} \int_{\mathbb{R}\mathbb{P}^{n-r-1}} \int_{\mathbb{R}} \chi(L_r \cap Q) \cosh^r \rho |\sinh^{n-r-1} \rho| d\rho dP_{[n-r]1} dP_{n-r}$$

where $dP_{[n-r]1}$ is the volume element of $\mathbb{R}\mathbb{P}^{n-r-1}$. The formula (2.5) states that $dP_{[n-r]1} dP_{n-r} = dP_{(n-r)[1]} dP_1$ where $dP_{(n-r)[1]}$ is the measure of the P_{n-r} containing P_1 . Then,

$$\begin{aligned} \int_{\mathcal{L}_r} \chi(L_r \cap Q) dL_r &= \int_{\mathbb{R}\mathbb{P}^{n-1}} \int_{G(n-r-1,(P_1)^\perp)} \int_{\mathbb{R}} \chi(L_r \cap Q) \cosh^r \rho |\sinh^{n-r-1} \rho| d\rho dP_{(n-r)[1]} dP_1 \\ &= \int_{\mathbb{R}\mathbb{P}^{n-1}} \int_{\mathbb{R}} \left(\int_{G(r,(P_1)^\perp)} \chi(L_r \cap Q) dP_r \right) \cosh^r \rho |\sinh^{n-r-1} \rho| d\rho dP_1. \end{aligned}$$

Now, given P_1 and ρ (i.e. given x), we projectivize (from x) the hyperplane L_{n-1} orthogonal to P_1 in x . The integral between brackets is the measure of the set of geodesic $(r - 1)$ -planes meeting a convex in \mathbb{S}^{n-2} . Applying proposition 4.2.1 we bound this measure in terms of the measure of $(r + s - 1)$ -planes meeting this convex in \mathbb{S}^{n-2} . We get

$$\int_{G(r,(P_1)^\perp)} \chi(L_r \cap Q) dP_r \leq \frac{O_{r+s-1} \cdots O_r}{O_{n-r-2} \cdots O_{n-r-s-1}} \int_{G(r+s,(P_1)^\perp)} \chi(L_{r+s} \cap Q) dP_{r+s}.$$

And we finish since $-R \leq \rho \leq R$ and so

$$\cosh^r \rho |\sinh^{n-r-1} \rho| \leq \tanh^s R \cosh^{r+s} \rho |\sinh^{n-r-s-1} \rho|.$$

□

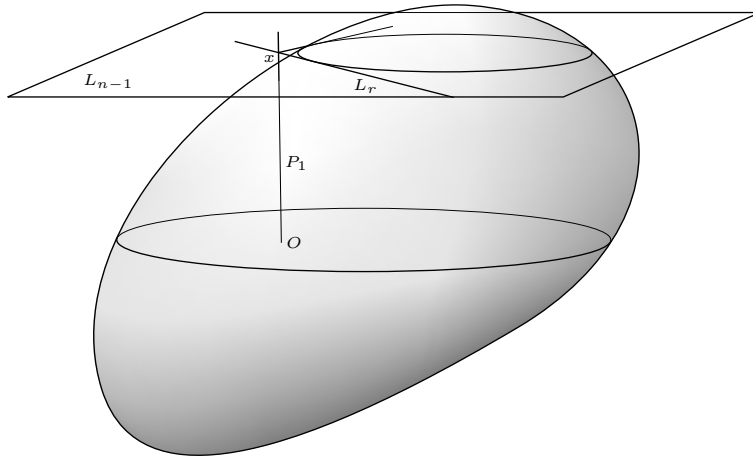

Figure 4.1: r -planes meeting Q

Corollary 4.2.4. *If $Q \subset B(R) \subset \mathbb{H}^n$ is convex, then*

$$W_r(Q) < \tanh^s R \frac{n-r}{n-r-s} W_{r+s}(Q).$$

In particular, since $\tanh R < 1$ we always have

$$W_r(Q) < \frac{n-r}{n-r-s} W_{r+s}(Q) \quad (4.6)$$

and this inequality is sharper as greater is Q .

But in the case $r = 0$, we can do it a little better.

Proposition 4.2.5. *Let $Q \subset \mathbb{H}^n$ be a convex set contained in $B(R)$, a radius R ball. Then*

$$\frac{W_0(Q)}{W_r(Q)} \leq \frac{W_0(B(R))}{W_r(B(R))} \quad (4.7)$$

with equality only for $Q = B(R)$.

Proof. Take as origin the center of the ball, and compute the volume of Q in polar coordinates

$$W_0(Q) = \int_{\mathbb{S}^{n-1}} \int_0^{l(u)} \sinh^{n-1} \rho d\rho du$$

where $l(u)$ is the distance to the origin of the intersection point of ∂Q with the geodesic ray $\gamma(u)$ starting with tangent vector $u \in \mathbb{S}^{n-1}$. Since all the hyperplanes orthogonal to $\gamma(u) \cap Q$ meet Q , we have

$$W_r(Q) \geq \frac{(n-r) \cdot O_{r-1} \cdots O_0}{n \cdot O_{n-2} \cdots O_{n-r-1}} \int_{\mathbb{S}^{n-1}} \int_0^{l(u)} \cosh^r \rho \sinh^{n-r-1} \rho d\rho du$$

On the other hand it is easy to see that the function

$$f(R) = \frac{W_r(B(R))}{W_0(B(R))} = \frac{(n-r) \cdot O_{r-1} \cdots O_0}{n \cdot O_{n-2} \cdots O_{n-r-1}} \frac{\int_0^R \cosh^r \rho \sinh^{n-r-1} \rho d\rho}{\int_0^R \sinh^{n-1} \rho d\rho}$$

is increasing. Thus, since $l(u) \leq R$, we have $f(l(u)) \leq f(R)$ and then

$$\begin{aligned} W_r(Q) &\geq \frac{(n-r) \cdot O_{r-1} \cdots O_0}{n \cdot O_{n-2} \cdots O_{n-r-1}} \int_{\mathbb{S}^{n-1}} \int_0^{l(u)} \cosh^r \rho \sinh^{n-r-1} \rho d\rho = \\ &= \int_{\mathbb{S}^{n-1}} f(l(u)) \int_0^{l(u)} \sinh^{n-1} \rho d\rho du \geq \\ &\geq \int_{\mathbb{S}^{n-1}} f(R) \int_0^{l(u)} \sinh^{n-1} \rho d\rho du = \frac{W_r(B(R))}{W_0(B(R))} W_0(Q). \end{aligned}$$

□

Observe that the inequalities we obtain run in the only possible sense. Indeed, an inequality in the style $W_{r+s}(Q) \leq cW_r(Q)$ could not be true. To see this take a convex domain Q contained in a geodesic $(n-r-s)$ -plane. Since Q is an $(n-r-s)$ -dimensional submanifold, by the Cauchy-Crofton formula in \mathbb{H}^n (2.6), we have that the measure of $(r+s)$ -planes meeting Q is a multiple of its $(n-r-s)$ -dimensional volume. Besides, the set of r -planes meeting Q has null measure. Thus $W_r(Q) = 0$ while $W_{r+s}(Q) > 0$.

4.3 Slice expectation for random geodesic planes

Consider the following problem on geometric probability: throw L_r , a geodesic r -plane of \mathbb{H}^n meeting a given convex domain $Q \subset \mathbb{H}^n$, randomly (according to the invariant measure dL_r). Consider the random consisting to measure the r -dimensional volume of the intersection of L_r with Q . We wonder about the expectation of this random variable

$$E[\text{vol}(L_r \cap Q)] = \frac{\int_{\mathcal{L}_r} \text{vol}(L_r \cap Q) dL_r}{\int_{\mathcal{L}_r} \chi(L_r \cap Q) dL_r}.$$

Santaló's formula (2.8) gives

$$\int_{\mathcal{L}_r} \text{vol}(L_r \cap Q) dL_r = \frac{O_{n-1} \cdots O_{n-r}}{O_{r-1} \cdots O_1} \cdot \text{vol}(Q).$$

And thus

$$E[\text{vol}(L_r \cap Q)] = \frac{(n-r) \cdot O_{n-1} O_0}{n \cdot O_{n-r-1}} \frac{\text{vol}(Q)}{W_r(Q)}. \quad (4.8)$$

We can compare these expectations for different dimensions r by using (4.7). Up to constants, the expectation is lower as greater is the dimension r .

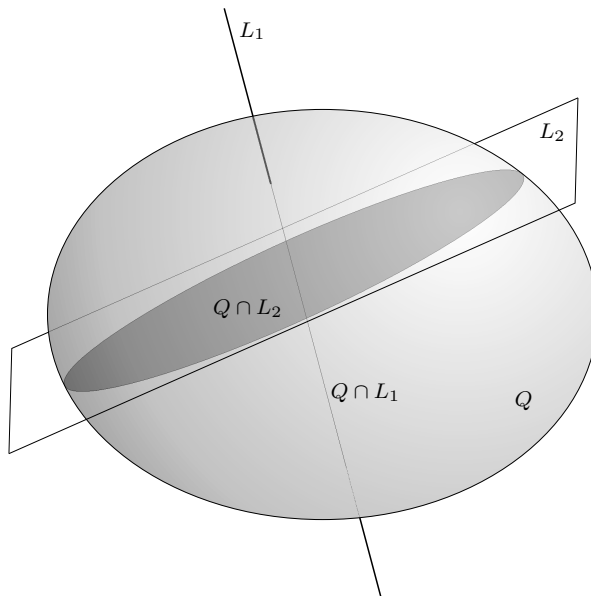

Figure 4.2: Volume of the slice for a plane and a line

Proposition 4.3.1. *For a convex domain $Q \subset \mathbb{H}^n$ contained in a radius R ball*

$$\frac{E[\text{vol}(Q \cap L_{r+s})]}{E[\text{vol}(Q \cap L_r)]} \leq \frac{E[\text{vol}(B(R) \cap L_{r+s})]}{E[\text{vol}(B(R) \cap L_r)]} < \frac{O_{n-r-1}}{O_{n-r-s-1}}$$

Proof. Immediate using (4.8) and (4.7) □

In particular we have

Corollary 4.3.2. *The expectation for the volume of the intersection of a random r -plane with a domain Q in \mathbb{H}^n is bounded by*

$$E[\text{vol}(L_r \cap Q)] < \frac{O_{n-1}}{O_{n-r-1}}.$$

Proof. Take the convex hull of Q and apply the previous proposition with $r = 0$. □

In \mathbb{H}^2 it was known that the expectation of a random chord is below π (cf. [San80]). In the rest of the cases our estimation seems to be new. As an example, let us mention that the expectation of a random chord in \mathbb{H}^3 is below π or that the expected area of a random plane slice is below 2π .

These results shock strongly to our euclidean intuition. It is clear that in \mathbb{R}^n these expectations are arbitrarily big if one takes the domains to be big enough. This is deduced from (4.1). A rough idea of what is going on in \mathbb{H}^n is the following. In negatively curved manifolds, the domains have a boundary greater than in curvature 0. This forces a big amount of planes intersecting the convex domain to keep close to the boundary, and thus to intersect a small region of the interior.

4.4 Inequalities between the mean curvature integrals

Now we are ready to find inequalities relating the mean curvature integrals of the boundary of a convex domain in \mathbb{H}^n . As will be seen, the key tool is the equality (3.14) which will show this way to be useful besides of pretty.

Proposition 4.4.1. *If $Q \subset \mathbb{H}^n$ is convex then, for $r > 1$*

$$\frac{M_r(\partial Q)}{\text{vol}(\partial Q)} > 1.$$

And this bound is sharp. For $r = 1$,

$$\frac{M_1(\partial Q)}{\text{vol}(\partial Q)} > \frac{n-2}{n-1}.$$

Thus for $r > 1$ the mean value of the mean curvature σ_r of the boundary of a convex set is greater than 1 and the mean value of σ_1 is also bounded below. This reflects again the idea that hypersurfaces of hyperbolic space need to provide more curvature than in euclidean geometry.

Proof. Thanks to equation (3.14), which relates the mean curvature integrals to the Quermassintegrale, and to inequality (4.6), we can do

$$\frac{M_r(\partial Q)}{M_0(\partial Q)} = \frac{W_{r+1}(Q) + \frac{r}{n-r+1}W_{r-1}(Q)}{W_1(Q)} > \frac{n-r-1}{n-1} + \frac{r}{n-r+1} \frac{n-r+1}{n-1} = 1.$$

This inequality is sharp since for sequences of balls with radius going to infinity $M_r/M_0 \rightarrow 1$ (cf. 1.10).

For $r = 1$, we use (3.14) and (4.2)

$$\frac{M_1(\partial Q)}{M_0(\partial Q)} = \frac{W_2(Q) + \frac{1}{n}W_0(Q)}{W_1(Q)} > \frac{W_2(Q)}{W_1(Q)} > \frac{n-2}{n-1}.$$

□

Remark. Even if it is not clear that the bound for M_1/M_0 is sharp, it must be noticed than one could not expect 1 to be the lower bound. Indeed, take a hyperplane L_{n-1} and $Q \subset L_{n-1}$ a ball of radius R inside L_{n-1} . Consider Q as a degenerate convex domain in \mathbb{H}^n ,

$$M_1(\partial Q) = n \left(W_2(Q) + \frac{1}{n}W_0(Q) \right) = \frac{O_1}{2(n-1)} \text{vol}(\partial B^{n-1}(R))$$

$$M_0(\partial Q) = \text{vol}(\partial Q) = 2\text{vol}(B^{n-1}(R))$$

then M_1/M_0 goes to $\frac{\pi(n-2)}{2(n-1)}$ when R grows. Thus, for $n = 3$ we have convex domains such that M_1/M_0 approaches $\pi/4$ which is below 1.

We can also compare the mean curvature integrals with the volume of the interior.

Corollary 4.4.2. *The following inequality holds for convex sets in \mathbb{H}^n*

$$\frac{M_i(\partial Q)}{V(Q)} > n-1$$

and the bound is sharp.

Proof. The case $i = 0$ is the known inequality (4.2). For $i > 1$, applying proposition 4.4.1 and (4.2)

$$\frac{M_i}{V} = \frac{M_i}{M_0} \cdot \frac{M_0}{V} > 1 \cdot (n-1).$$

For $i = 1$

$$\frac{M_1}{V} = \frac{n(W_2 + \frac{1}{n}W_0)}{W_0} > n \frac{n-2}{n} + 1 = n-1.$$

□

In a similar way, we can find estimations for any quotient of mean curvature integrals.

Proposition 4.4.3. *If $Q \subset \mathbb{H}^n$ is convex then, for $i \geq 0$ and $j \geq 2$ such that $i+j \leq n-1$,*

$$\frac{M_{i+j}(\partial Q)}{M_i(\partial Q)} > 1$$

and the bound is sharp. For $j = 1$,

$$\frac{M_{i+1}(\partial Q)}{M_i(\partial Q)} > \frac{n-i-2}{n-i-1}.$$

Proof. Use again the equation (3.14) and the inequality (4.6)

$$\begin{aligned}
 \frac{M_{i+j}(\partial Q)}{M_i(\partial Q)} &= \frac{W_{i+j+1}(Q) + \frac{i+j}{n-i-j+1}W_{i+j-1}(Q)}{W_{i+1}(Q) + \frac{i}{n-i+1}W_{i-1}(Q)} > \\
 &= \frac{\frac{n-i-j-1}{n-i-j+1}W_{i+j-1}(Q) + \frac{i+j}{n-i-j+1}W_{i+j-1}(Q)}{W_{i+1}(Q) + \frac{i}{n-i+1}\frac{n-i+1}{n-i-1}W_{i+1}(Q)} = \\
 &= \frac{n-i-1}{n-i-j+1} \frac{W_{i+j-1}(Q)}{W_{i+1}(Q)} > \frac{n-i-1}{n-i-j+1} \frac{n-i-j+1}{n-i-1} = 1. \quad (4.9)
 \end{aligned}$$

This is sharp since for a sequence of balls the quotient M_i/M_{i+j} approaches 1 as the radius grows to ∞ .

For $j = 1$,

$$\frac{M_{i+1}(\partial Q)}{M_i(\partial Q)} = \frac{W_{i+2}(Q) + \frac{i+1}{n-i}W_i(Q)}{W_{i+1}(Q) + \frac{i}{n-i+1}W_{i-1}(Q)}.$$

And we finish since

$$\frac{W_{i+2}(Q)}{W_{i+1}(Q)} > \frac{n-i-2}{n-i-1} \quad \frac{\frac{i+1}{n-i}W_i(Q)}{\frac{i}{n-i+1}W_{i-1}(Q)} > \frac{i+1}{i} > 1 > \frac{n-i-2}{n-i-1}.$$

□

Remark. Note that the bound for the quotient M_{n-1}/M_{n-2} is 0. In section 4.5 we will find convex domains for which this quotient takes arbitrarily small values.

In short, we have found lower bounds for all the quotients M_{i+j}/M_i . Except from the case M_{n-1}/M_{n-2} , these bounds are strictly positive, and they are sharp when $j > 1$.

A natural question is to find upper bounds for such quotients. But it is immediate to see that these quotients are not bounded from above. For instance, if Q is a radius R ball,

$$\frac{M_{i+j}(\partial Q)}{M_i(\partial Q)} = \frac{\cosh^j R}{\sinh^j R}$$

which is arbitrarily big if R is small enough.

One can also argue noting that in euclidean space there are examples of arbitrarily small convex sets with arbitrarily big M_{i+j}/M_i . Since in *small* neighborhoods of a point the metrics of \mathbb{H}^n and \mathbb{R}^n are very *similar*, there must be convex bodies in hyperbolic space with M_{i+j}/M_i .

However, if we restrict ourselves to convex bodies that are *big* in some sense, it is possible to find some upper bounds for M_{i+j}/M_i .

Consider the 2-dimensional case. Given a convex $Q \subset \mathbb{H}^2$ domain, $M_1(\partial Q)$ is the geodesic curvature integral of the boundary. Using the Gauss-Bonnet formula, we have that

$$M_1(\partial Q) = 2\pi + \text{vol}(Q).$$

Thus

$$\frac{M_1(\partial Q)}{M_0(\partial Q)} = \frac{2\pi + \text{vol}(Q)}{\text{vol}(\partial Q)}.$$

We have seen that the area of a convex domain is below the length of its boundary. Thus, if the convex set is big enough, then $M_1(\partial Q)/M_0(\partial Q)$ can not be much greater than 1. To be more precise, if (Q_r) is a sequence of convex sets expanding over the hyperbolic plane, then

$$\lim \frac{M_1(\partial Q_r)}{M_0(\partial Q_r)} \leq 1.$$

Definition 4.4.1. A sequence of convex sets (Q_r) of \mathbb{H}^n is said to *expand over the whole hyperbolic space* when $\cup_r Q_r = \mathbb{H}^n$.

For such sequences we have the following upper bounds.

Proposition 4.4.4. *Let (Q_r) be a sequence of convex sets expanding over the whole hyperbolic space. Then*

$$\begin{aligned} i) \quad & \lim_{n \rightarrow \infty} \frac{M_{n-1}(\partial Q_r)}{M_{n-2}(\partial Q_r)} \leq n - 1 \\ ii) \quad & \lim_{n \rightarrow \infty} \frac{M_{n-1}(\partial Q_r)}{M_{n-3}(\partial Q_r)} \leq \frac{n - 1}{2} \end{aligned}$$

Proof. We have that

$$\frac{M_{n-1}(\partial Q_r)}{M_{n-2}(\partial Q_r)} = \frac{W_n(Q_r) + \frac{n-1}{2}W_{n-2}(Q_r)}{W_{n-1}(Q_r) + \frac{n-2}{3}W_{n-3}(Q_r)}$$

But $W_n(Q_r)$ does not depend on r but is always O_{n-1}/n . On the other hand $W_{n-1}(Q_r)$, $W_{n-2}(Q_r)$ and $W_{n-3}(Q_r)$ go to infinity when Q_r expands over \mathbb{H}^n . Therefore

$$\begin{aligned} \lim_{n \rightarrow \infty} \frac{M_{n-1}(\partial Q_r)}{M_{n-2}(\partial Q_r)} &= \frac{n-1}{2} \lim_{n \rightarrow \infty} \frac{W_{n-2}(Q_r)}{W_{n-1}(Q_r) + \frac{n-2}{3}W_{n-3}(Q_r)} \leq \\ &\leq \frac{n-1}{2} \lim_{n \rightarrow \infty} \frac{W_{n-2}(Q_r)}{W_{n-1}(Q_r)} \end{aligned}$$

Bearing in mind that $W_{n-2}/W_{n-1} < 2$, we have proved *i*). Analogously one proves *ii*).

$$\frac{M_{n-1}(\partial Q_r)}{M_{n-3}(\partial Q_r)} \sim \frac{n-1}{2} \frac{W_{n-2}(Q_r)}{W_{n-2}(Q_r) + \frac{n-3}{4}W_{n-4}(Q_r)} \leq \frac{n-1}{2}.$$

□

The second inequality is sharp, as next section shows by giving examples of sequences attaining the bound. The same sequences show that the other quotients M_{i+j}/M_i can not be bounded above even if the convex set is big.

Concerning (4.5) we can improve it when the convex sets are assumed to be in hyperbolic space (instead of a manifold with bounded negative curvature). Recall that in the definition 1.1.2 one introduces the concept of λ -convexity. One fact to have in mind, which is easily seen, is that for $\lambda > 1$ every λ -convex set is contained in a ball of radius $\text{arctanh} \lambda$. Then we will only care about the values $0 \leq \lambda \leq 1$.

Proposition 4.4.5. *If Q_r is a sequence of λ -convex sets expanding over the whole \mathbb{H}^n , then*

$$\lim_{r \rightarrow \infty} \frac{M_1(\partial Q_r)}{\text{vol}(\partial Q_r)} > \frac{\lambda + n - 2}{n - 1}.$$

Proof. Using (4.6) and (4.3),

$$\lim_{r \rightarrow \infty} \frac{M_1(\partial Q_r)}{\text{vol}(\partial Q_r)} = \lim_{r \rightarrow \infty} \frac{W_2(Q_r)}{W_1(Q_r)} + \frac{\text{vol}(Q_r)}{\text{vol} \partial Q_r} > \frac{n - 2}{n - 1} + \frac{\lambda}{n - 1}.$$

□

4.5 Examples

In this section we construct a family of examples whose behaviour is extreme in many senses. They will show many of the inequalities seen in this chapter to be sharp.

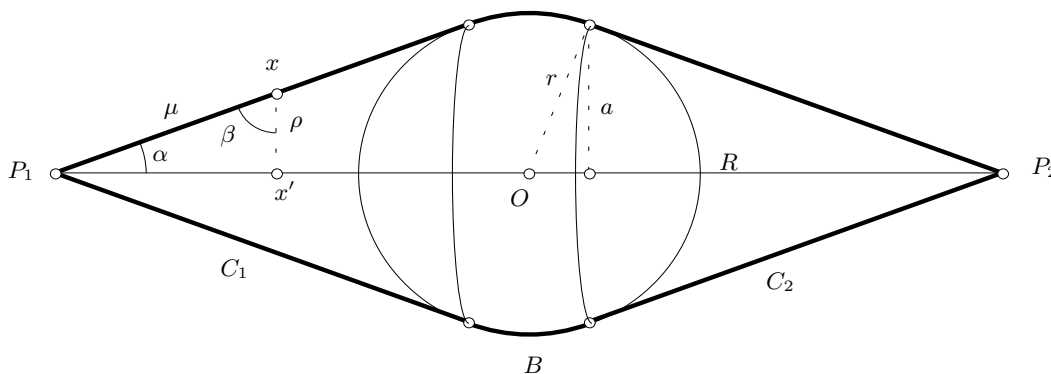

Figure 4.3: The convex domain $Q(r, R)$

Consider a radius $r > 0$ ball centered at a point $O \in \mathbb{H}^n$. Let P_1 and P_2 be the endpoints of a segment of length $2R$ having its midpoint at O . Suppose $R > r$ and take the convex hull of the ball $B_O(r)$ and the points P_1, P_2 . Denote by $Q(r, R)$ this convex hull (cf. figure 4.3). The union of all the segments going from P_1 or P_2 to a point of tangency with $\partial B_O(r)$ defines two cones, C_1 and C_2 . The set of all such tangency points consists of two $(n - 2)$ -dimensional spheres of radius a contained in $(n - 1)$ -planes orthogonal to the segment P_1P_2 . If B denotes the region of $\partial B_O(r)$ bounded by these two spheres, the boundary of $Q(r, R)$ splits in three pieces; that is C_1, B and C_2 .

Since $\partial Q(r, R)$ is not everywhere smooth, we compute the mean curvature integrals $M_i(\partial Q(r, R))$ approximating $Q(r, R)$ by convex sets of smooth boundary. This way one

easily checks that for $i < n - 1$ the vertices do not provide mean curvature and we have

$$M_i(\partial Q(r, R)) = \int_{\partial Q(r, R)} \sigma_i(x) dx.$$

In the case $i = n - 1$, we can compute $M_{n-1}(\partial Q(r, R))$ by directly measuring the set of support hyperplanes of $Q(r, R)$. Since the support hyperplanes at every vertex have a measure below $O_{n-1}/2$, we have

$$M_{n-1}(\partial Q(r, R)) < \int_{\partial Q(r, R)} \sigma_{n-1}(x) dx + O_{n-1}.$$

For every $r \in \mathbb{N}$ take $R = e^{2r}$ and consider the sequence of convex domains $Q_r = Q(r, e^{2r})$ which expands over the whole \mathbb{H}^n .

Proposition 4.5.1. *The quotients for the mean curvature integrals of the sequence defined above have the following asymptotic values*

$$\lim_{r \rightarrow \infty} \frac{M_{n-2}(\partial Q(r))}{M_i(\partial Q(r))} = \infty \quad \lim_{r \rightarrow \infty} \frac{M_i(\partial Q(r))}{M_j(\partial Q(r))} = 1$$

for $i, j \neq n - 2$.

Proof. For the cone C_1 , let c and α be respectively the length of the generatrix and the angle it makes with the rotation axis P_1P_2 . In a point $x \in C_1$, let μ be the distance to the vertex P_1 . If x' is the orthogonal projection of x over the segment P_1P_2 , we can determine x by its polar coordinates $\rho, \theta_1, \dots, \theta_{n-2}$ centered at x' inside the hyperplane orthogonal to P_1P_2 . The hyperbolic trigonometry formulas (1.2) give

$$\sinh \rho = \sin \alpha \sinh \mu.$$

Now, C_1 is parametrized by the coordinates $(\mu, \theta_1, \dots, \theta_{n-2})$ and the volume element is

$$dx = (\sin \alpha \sinh \mu)^{n-2} d\mu d\theta.$$

Clearly, at any point $x \in C_1$, the generatrix's direction is principal with normal curvature 0. By the Meusnier theorem, for every direction orthogonal to the generatrix, the normal curvature is $\sin \beta \coth \rho$ where β denotes the inner angle between $x'x$ and the generatrix. Again by hyperbolic trigonometry we get $\cos \alpha = \cosh \rho \sin \beta$. Thus, the i -th curvature integral of C_1 is

$$\begin{aligned} M_i(C) &= \int_{S^{n-2}} \int_0^c \binom{n-2}{i} \binom{n-1}{i}^{-1} (\sin \beta \coth \rho)^i (\sin \alpha \sinh \mu)^{n-2} d\mu d\theta = \\ &= \frac{n-i-1}{n-1} O_{n-2} \cos^i \alpha \sin^{n-i-2} \alpha \int_0^c \sinh^{n-i-2} \mu d\mu. \end{aligned}$$

Note that when c grows to infinity, for $m \geq 1$

$$\int_0^c \sinh^m s ds \sim \frac{\cosh^m c}{m}.$$

Now take $R(r) = e^{2r}$. Since R , r and c are the sides of a right angle triangle

$$\cosh c = \cosh e^{2r} / \cosh r \sim e^{e^{2r}-r}$$

$$\alpha \sim \sin \alpha = \sinh r / \sinh e^{2r} \sim e^{r-e^{2r}}.$$

Then, for $i \neq n-2$,

$$\begin{aligned} \lim_{r \rightarrow \infty} M_i C_1 &= \lim_{r \rightarrow \infty} \frac{n-i-1}{n-1} O_{n-2} e^{(n-i-2)(e^{2r}-r)} \frac{e^{(n-i-2)(r-e^{2r})}}{(n-i-2)} = \\ &= \frac{n-i-1}{(n-1)(n-i-2)} O_{n-2}. \end{aligned}$$

Therefore, when r goes to infinity,

$$M_i(\partial Q) \sim M_i(\partial B(r)).$$

And since the proportion of $B(r)$ over the whole ball goes to 1,

$$M_i(\partial Q) \sim M_i(\partial B_O(r)).$$

With this we have found the second limit of the statement.

Finally, $M_{n-2}(\partial Q)/M_i(\partial Q)$ goes to infinity since

$$M_{n-2}(\partial Q) > M_{n-2}(C_1) = \frac{O_{n-2}}{n-1} \cos \alpha \cdot c \sim \frac{O_{n-2}}{n-1} e^{2r}.$$

□

Given $\epsilon > 0$, take the parallel convex domains $Q_r^\epsilon = \{x \in \mathbb{H}^n \mid d(c, Q) \leq \epsilon\}$ at distance ϵ from Q_r .

Proposition 4.5.2. For $i, j = 0, \dots, n-1$

$$\lim_{r \rightarrow \infty} \frac{M_i(\partial Q_r^\epsilon)}{M_j(\partial Q_r^\epsilon)} = \frac{i \coth^{i-2} \epsilon + (n-i-1) \coth^i \epsilon}{j \coth^{j-2} \epsilon + (n-j-1) \coth^j \epsilon}$$

Proof. Use the Steiner formula for the mean curvature integrals (1.12)

$$\begin{aligned} \lim_{r \rightarrow \infty} \frac{M_i(\partial Q_r^\epsilon)}{M_j(\partial Q_r^\epsilon)} &= \lim_{r \rightarrow \infty} \frac{\binom{n-1}{i}^{-1} \sum_{k=0}^{n-1} \binom{n-1}{k} M_k(\partial Q_r) \phi_{ik}(\epsilon)}{\binom{n-1}{j}^{-1} \sum_{k=0}^{n-1} \binom{n-1}{k} M_k(\partial Q_r) \phi_{jk}(\epsilon)} = \\ &= \lim_{r \rightarrow \infty} \frac{\binom{n-1}{j} M_{n-2}(\partial Q_r) \phi_{i, n-2}(\epsilon)}{\binom{n-1}{i} M_{n-2}(\partial Q_r) \phi_{j, n-2}(\epsilon)} = \frac{\binom{n-1}{j} \phi_{i, n-2}(\epsilon)}{\binom{n-1}{i} \phi_{j, n-2}(\epsilon)} \end{aligned}$$

where

$$\phi_{i,n-2}(\epsilon) = \binom{n-2}{i-1} \sinh^{n-i} \epsilon \cosh^{i-1} \epsilon + \binom{n-2}{i} \sinh^{n-i-2} \epsilon \cosh^{i+1} \epsilon$$

□

These examples are interesting since they show that M_{i+j}/M_i can be bounded above only in the cases contained in proposition 4.4.4. They also show the inequality *ii*) of this proposition to be sharp. Besides, we have seen that the only quotient M_{i+j}/M_i for which we had a null lower bound ($i = n - 2$ and $i + j = n - 1$), can really take arbitrarily small values.

Corollary 4.5.3. *For every $1 \leq L \leq \infty$, there exists some sequence (Q_r) of convex domains expanding over the whole \mathbb{H}^n such that*

$$\lim_{r \rightarrow \infty} \frac{M_i(\partial Q_r)}{M_j(\partial Q_r)} = L$$

except from the cases $i = n - 1$ and $j = n - 2, n - 3$. For every $0 \leq \delta \leq 1$ there is a sequence (Q_r) of convex domains expanding over the whole \mathbb{H}^n such that

$$\lim_{r \rightarrow \infty} \frac{M_{n-1}(\partial Q_r)}{M_{n-2}(\partial Q_r)} = \delta.$$

For every $1 \leq \alpha \leq \frac{n-1}{2}$ there is some sequence (Q_r) of convex domains expanding over the whole \mathbb{H}^n such that

$$\lim_{r \rightarrow \infty} \frac{M_{n-1}(\partial Q_r)}{M_{n-3}(\partial Q_r)} = \alpha.$$

Proof. It is enough to study the images of the functions

$$f_{ij}(\epsilon) = \frac{i \coth^{i-2} \epsilon + (n - i - 1) \coth^i \epsilon}{j \coth^{j-2} \epsilon + (n - j - 1) \coth^j \epsilon}.$$

Indeed,

$$\begin{aligned} f_{n-1,n-2}((0, \infty)) &= (0, 1) \\ f_{n-1,n-3}((0, \infty)) &= \left(1, \frac{n-1}{2}\right) \\ f_{ij}((0, \infty)) &= (1, \infty) \end{aligned}$$

for the rest of values of i and j . Thus, for the non extremal values of L , δ and α , there is some $\epsilon > 0$ such that Q_r^ϵ is the desired sequence. For $L = \infty$, $\delta = 0$ or $\alpha = (n - 1)/2$ take the sequence $\epsilon_m = 1/m$ and a sequence r_m such that

$$\left| \frac{M_i(\partial Q_{r_m}^{\epsilon_m})}{M_j(\partial Q_{r_m}^{\epsilon_m})} - f_{ij}(\epsilon_m) \right| < \frac{1}{m}.$$

Finally, the quotients tend to 1 if for instance Q_r is a radius r ball. □

Thus, among all the bounds we have given, the only ones that may be not sharp are those of the second part of proposition 4.4.3 and of the first part of proposition 4.4.4. The most interesting of these ‘maybe-non-sharp’ cases is the estimation

$$\frac{M_1(\partial Q)}{\text{vol}(\partial Q)} \geq \frac{n-2}{n-1}.$$

Recall that we have only found examples approaching $\frac{\pi(n-2)}{2(n-1)}$ and 1.

Finally, the sequences Q_r^ϵ also prove that inequalities (4.3) for the limit of the quotient $\text{vol}(Q)/\text{vol}(\partial Q)$ in sequences of λ -convex domains are sharp. Indeed, given $0 \leq \lambda < 1$, take $\epsilon > 0$ such that $\tanh \epsilon = \lambda$. Then the boundary of Q_r^ϵ has normal curvature greater than λ everywhere and we have seen that

$$\lim_{r \rightarrow \infty} \frac{\text{vol}(Q_r^\epsilon)}{\text{vol}(\partial Q_r^\epsilon)} = \frac{\lambda}{n-1}.$$

This way we have generalized to any dimension the results of [GR85] and [GR99].

Chapter 5

Integral geometry of horospheres and equidistants

5.1 Introduction

So far we have been dealing with kinematic formulas involving totally geodesic planes. We also know about kinematic formulas where these planes are replaced by compact submanifolds. Thus, we have kinematic formulas for hyperplanes and also for spheres. This can be satisfactory in euclidean geometry since these are the interesting hypersurfaces in euclidean space. But it has already been said that in hyperbolic geometry there is a kind of gap between geodesic hyperplanes and spheres. Recall that while hyperplanes have null normal curvature, the normal curvature of spheres in \mathbb{H}^n is greater than 1. This gap is filled by two kinds of hypersurfaces called horospheres and equidistants. Recall that geodesic hyperplanes, spheres, horospheres and equidistants are the four types of totally umbilical hypersurfaces in hyperbolic space. We already said that horospheres are obtained when the center of a sphere moves infinitely far away from a fixed point of the sphere, and they have constant normal curvature 1. On the other hand, equidistants are the geometric locus of points at a given distance from a hyperplane and have constant normal curvature below 1. Both horospheres and equidistants are non-compact and thus one can not apply them the kinematic formulas of Poincaré and Blaschke.

It is natural then to look for kinematic formulas for horospheres and equidistants of \mathbb{H}^n . Santaló started to do this for horospheres in \mathbb{H}^2 and \mathbb{H}^3 (cf. [San67, San68]). Recently, Gallego, Martínez Naveira and the author (cf. [GNS]), have extended his results to horospheres in any dimension. The main ideas, already in Santaló's work, are to approximate horospheres by balls with growing radius, and to use the fact that the intrinsic geometry of horospheres is euclidean. Finally the Gauss-Bonnet theorem in constant curvature spaces allows to obtain the measure of horospheres meeting an h -convex set (convex with respect to horospheres). In this chapter we pursue this study by giving kinematic formulas involving also equidistant hypersurfaces. Concretely, we will find kinematic formulas for totally umbilical hypersurfaces of \mathbb{H}^n with any normal curvature λ . Thus, for $\lambda = 0$ we will recover the classical formulas for geodesic hyperplanes, for

$\lambda > 1$ we will have the case of spheres which is deduced from the kinematic formulas of Poincaré and Blaschke, and for $\lambda = 1$ one will recover the results of [GNS]. Finally, the new case is that of $0 < \lambda < 1$, where equidistant hypersurfaces are involved.

Then the formulas for horospheres will be used to deduce some properties of h -convex domains. We will also look at the expectation of the volume of the slice of a domain with a random horosphere or equidistant. We will see that, as for geodesic hyperplanes, this expectation is bounded above.

5.2 Definitions and invariant measures

Recall that a point in a hypersurface is called *umbilical* when the normal curvatures are the same in all the directions at this point. A hypersurface such that all his points are umbilical is called *totally umbilical*. In constant curvature spaces, totally umbilical hypersurfaces have constant normal curvature (cf. for instance [dC92]). On the other hand, such hypersurfaces are the boundary of convex regions. Taking the unit normal vector which is interior to that region, the normal curvature will be always positive.

Definition 5.2.1. For $\lambda \geq 0$, a complete totally umbilical hypersurface with normal curvature λ is called a λ -*hyperplane* of \mathbb{H}^n . Denote by $\mathcal{L}_{n-1}^\lambda$ the set of all such λ -hyperplanes of \mathbb{H}^n .

This definition includes, for $\lambda = 1$, horospheres, and for $\lambda = 0$, geodesic hyperplanes. The case $\lambda > 1$ contains the spheres of radius $\operatorname{arctanh}(1/\lambda)$. For $\lambda < 1$, the tube at distance $\operatorname{arctanh}\lambda$ around a geodesic hyperplane has two connected components each of which is a λ -hyperplane. With such a description it becomes clear that $\mathcal{L}_{n-1}^\lambda$ is a homogeneous space of the isometry group G for every λ .

An important fact that can be seen through the Gauss equation is that with the metric induced by \mathbb{H}^n , a λ -hyperplane is a complete simply connected Riemann manifold with constant sectional curvature $\lambda^2 - 1$. In particular the horospheres are euclidean spaces and the equidistants with normal curvature λ are hyperbolic spaces of constant sectional curvature $\lambda^2 - 1$.

Remark. It is not hard to see that in the hyperboloid model the λ -hyperplanes are intersections of \mathbb{H}^n with affine hyperplanes of the form

$$\{x \in \mathbb{R}^{n+1} \mid L(x, y) = -\lambda\}$$

where $L(y, y) = 1$.

Now we introduce an analogue of λ -hyperplanes for higher codimensions. Since a geodesic r -plane $L_r \subset \mathbb{H}^n$ is isometric to \mathbb{H}^r , it has sense to consider the λ -hyperplanes of L_r .

Definition 5.2.2. A λ -hyperplane of some geodesic $(r + 1)$ -plane in \mathbb{H}^n is called a λ -*geodesic r -plane*. We define \mathcal{L}_r^λ to be the set of all such λ -geodesic r -planes.

Every λ -geodesic r -plane is contained in one only geodesic $(r+1)$ -plane. Besides, it can be seen that it is also contained in one only λ -hiperplane.

The isometry group G acts transitively on \mathcal{L}_r^λ . Indeed, we know that it acts transitively on the set of geodesic $(r+1)$ -planes. The isotropy subgroup of one of these planes is like the isometry group of \mathbb{H}^{r+1} , so it acts transitively on the set of λ -hyperplanes it conatins. Thus, take the geodesic $(r+1)$ -plane L_{r+1} defined by the point e_0 and $\langle e_1, \dots, e_{r+1} \rangle$. Choose L_r^λ the λ -geodesic r -plane by e_0 , contained in L_{r+1} and such that e_{r+1} is the normal vector in e_0 pointing towards the convexity of L_r^λ . Let H_r^λ be the subgroup of isometries leaving it invariant. Now, \mathcal{L}_r^λ is identified to the homogeneous space G/H_r^λ . This defines a projection $\pi_r^\lambda : G \longrightarrow \mathcal{L}_r^\lambda$.

Proposition 5.2.1. *For $0 \leq \lambda \neq 1$ the space \mathcal{L}_r^λ admits a semi-riemannian metric $\langle \cdot, \cdot \rangle_r^\lambda$ invariant under isometries. This metric is such that*

$$(\pi_r^\lambda)^* \langle \cdot, \cdot \rangle_r^\lambda = \sum_{i=1}^r \frac{(\omega_i^{r+1} - \lambda \omega_0^i) \otimes (\omega_i^{r+1} - \lambda \omega_0^i)}{1 - \lambda^2} + \sum_{1 \leq i \leq (r+1) < j \leq n} \omega_i^j \otimes \omega_i^j - \sum_{j=r+1}^n \omega_0^j \otimes \omega_0^j. \quad (5.1)$$

For every $\lambda \geq 0$ the space \mathcal{L}_r^λ admits a measure $d\mathcal{L}_r^\lambda$ invariant under isometries which is defined by

$$(\pi_r^\lambda)^* d\mathcal{L}_r^\lambda = \bigwedge_{h=1}^r (\omega_h^{r+1} - \lambda \omega_0^h) \wedge \left(\bigwedge_{1 \leq i \leq (r+1) < j \leq n} \omega_i^j \right) \wedge \bigwedge_{k=r+1}^n \omega_0^k \quad (5.2)$$

Proof. Let us look for the vertical part of π_r^λ . Let g be a frame such that $\pi(g) = L_r^\lambda$. It is clear that if \bar{g} another frame with

$$\bar{g}_0 = g_0 \quad \langle \bar{g}_1, \dots, \bar{g}_r \rangle = \langle g_1, \dots, g_r \rangle \quad \langle \bar{g}_{r+2}, \dots, \bar{g}_n \rangle = \langle g_{r+2}, \dots, g_n \rangle,$$

then $\pi_r^\lambda(\bar{g}) = \pi_r^\lambda(g)$. Thus, $v_i^j \in \ker d\pi_r^\lambda$ for $1 \leq i, j \leq r$ or $r+2 \leq i, j \leq n$. Let $x(t)$ be the geodesic line in L_r^λ leaving from g_0 with direction g_i ($1 \leq i \leq r$). Shift $x(t)$ to a curve $g(t) \subset G$ such that $\pi_r^\lambda(g(t)) \equiv L_r^\lambda$. Since all the normal curvatures of L_r^λ are equal to λ ,

$$\nabla_{g_i} g_{r+1} = \lambda g_i.$$

Then $0 = d\pi_r^\lambda(\dot{g}(0)) = d\pi_r^\lambda(v_0^i + \lambda v_i^{r+1})$ and we have

$$T_g gH = \ker d\pi_r^\lambda = \langle v_0^i + \lambda v_i^{r+1} \mid i = 1, \dots, r \rangle \oplus \langle v_i^j \mid 1 \leq i < j \leq r \text{ o } r+2 \leq i < j \leq n \rangle$$

and the orthogonal space with respect to the metric in G is

$$(T_g gH)^\perp = (\ker d\pi_r^\lambda)^\perp = \langle v_i^{r+1} + \lambda v_0^i \mid i = 1, \dots, r \rangle \oplus \langle v_0^h \mid h = r+1, \dots, n \rangle \oplus \langle v_i^j \mid 1 \leq i \leq r+1 < j \leq n \rangle$$

Thus, we endow \mathcal{L}_r^λ of the metric (1.6) of G restricted to $(\ker d\pi_r^\lambda)^\perp$. The expression (5.1) is this restriction since it vanishes on $\ker d\pi_r^\lambda$ and coincides with the metric of G

over a basis of $(\ker d\pi_r^\lambda)^\perp$. This metric is constant along the fibres and it is invariant because the metric on G is bi-invariant. On the other hand, the form (5.2) defines an invariant measure in the space of r -dimensional λ -planes since it is closed and it is the wedge of 1-forms vanishing on gH (cf. [San76, p.166]). \square

Remark. Note that from the expression (5.2) one deduces that

$$dL_r^\lambda = dL_{[r+1]r}^\lambda \wedge dL_{r+1} \quad (5.3)$$

where dL_{r+1} is the measure of \mathcal{L}_{r+1} and $dL_{[r+1]r}^\lambda$ denotes the measure of λ -geodesic r -planes contained in the geodesic $(r+1)$ -plane L_{r+1} .

In polar coordinates, the measure of λ -hyperplanes is

$$dL_{n-1}^\lambda = (\cosh \rho - \lambda \sinh \rho)^{n-1} d\rho dS^{n-1} \quad (5.4)$$

where ρ is the distance from the origin to L_{n-1}^λ , taken with negative sign when the origin is outside the convex region bounded by L_{n-1}^λ .

5.3 Volume of intersections with λ -geodesic planes

In this section we generalize to λ -geodesic planes the formula (2.8) for the integral of the volume of intersections with geodesic planes. We start with the case of codimension 1.

Proposition 5.3.1. *Let S be a compact q -dimensional submanifold of \mathbb{H}^n , piecewise C^1 , possibly with boundary. Then*

$$\int_{\mathcal{L}_{n-1}^\lambda} \text{vol}_{q-1}(L_{n-1}^\lambda \cap S) dL_{n-1}^\lambda = \frac{O_n O_{q-1}}{O_q} \cdot \text{vol}_q(S).$$

Proof. Consider the manifold

$$E(S) = \{(L_{n-1}^\lambda, p) \in \mathcal{L}_{n-1}^\lambda \times S \mid p \in L_{n-1}^\lambda \cap S\}.$$

For almost every (L_{n-1}^λ, p) , i.e out of a null measure subset of $E(S)$, the intersection $L_{n-1}^\lambda \cap S$ is a C^1 submanifold in a neighborhood of p . Denote by dx_{q-1} the volume element of this submanifold. Now,

$$\int_{\mathcal{L}_{n-1}^\lambda} \text{vol}_{q-1}(L_{n-1}^\lambda \cap S) dL_{n-1}^\lambda = \int_{E(S)} dx_{q-1} \wedge dL_{n-1}^\lambda$$

where dL_{n-1}^λ denotes the volume element on $\mathcal{L}_{n-1}^\lambda$ and also its pull-back to $E(S)$. Consider now,

$$G(S) = \{g \in G \mid g_0 \in S \cap L_{n-1}^\lambda \quad g_1, \dots, g_{q-1} \in T_{g_0}(S) \quad g_{q+1}, \dots, g_{n-1} \perp T_{g_0}S\}$$

and the projection $\pi : G(S) \longrightarrow E(S)$ mapping the frame g to $(\pi_{n-1}^\lambda(g), g_0)$. Thus,

$$\pi^*(dx_{q-1} \wedge dL_{n-1}^\lambda) = \bigwedge_{h=1}^{q-1} \omega_0^h \wedge \omega_0^n \wedge \bigwedge_{i=1}^{n-1} (\omega_i^n - \lambda \omega_0^i) = \bigwedge_{h=1}^{q-1} \omega_0^h \wedge \omega_0^n \wedge \bigwedge_{i=1}^{q-1} \omega_i^n \wedge \bigwedge_{i=q}^{n-1} (\omega_i^n - \lambda \omega_0^i)$$

Given $g \in G(S)$ take $\bar{g} \in G(S)$ such that

$$\bar{g}_0 = g_0 \quad \dots \quad \bar{g}_{q-1} = g_{q-1} \quad \text{i} \quad \bar{g}_q \in T_{g_0} S$$

But for every $v \in T_g G(S)$,

$$\omega_0^i(v) = \langle v, v_0^i \rangle = \langle d\pi_0 v, g_i \rangle = 0 \quad q < i < n$$

$$\bar{\omega}_0^i(v) = \langle v, v_0^i \rangle = \langle d\pi_0, g_i \rangle = 0 \quad q < i.$$

Then,

$$\begin{aligned} \omega_0^n &= \sum_{i=q}^n \langle \bar{g}_i, g_n \rangle \bar{\omega}_0^i = \langle \bar{g}_q, g_n \rangle \bar{\omega}_0^q \\ \omega_0^q &= \sum_{i=q}^n \langle \bar{g}_i, g_q \rangle \bar{\omega}_0^i = \langle \bar{g}_q, g_q \rangle \bar{\omega}_0^q \end{aligned}$$

Since we are dealing with measures we do not have to care about the signs, and we can write

$$\pi^*(dx_{q-1} \wedge dL_{n-1}^\lambda) = \langle \bar{g}_q, g_n \rangle \bigwedge_{h=1}^{q-1} \omega_0^h \wedge \bar{\omega}_0^q \wedge \bigwedge_{i=1}^{n-1} \omega_i^n = |\sin \theta| dx_q \wedge du \quad (5.5)$$

where du is the volume element on \mathbb{S}^{n-1} corresponding to the normal vector to L_{n-1}^λ in x , dx_q corresponds to the volume element of S and θ is the angle between S and L_{n-1}^λ in x . Integrating both members of (5.5) we get

$$\int_{E(S)} dx_{q-1} \wedge dL_{n-1}^\lambda = \int_{G(S)} \pi^*(dx_{q-1} \wedge dL_{n-1}^\lambda) = \int_{\mathbb{S}^{n-1}} |\sin \theta| du \cdot \int_S dx_q.$$

Finally one computes that

$$\int_{\mathbb{S}^{n-1}} |\sin \theta| dS^{n-1} = \frac{O_n O_{q-1}}{O_q}.$$

□

Consider the case of λ -geodesic planes with higher codimension.

Proposition 5.3.2. *Let S be a q -dimensional compact submanifold in \mathbb{H}^n , piecewise C^1 , maybe with boundary. Then for $r + q \geq n$*

$$\int_{\mathcal{L}_r^\lambda} \text{vol}_{r+q-n}(L_r^\lambda \cap S) dL_r^\lambda = \frac{O_n \cdots O_{n-r-1} O_{r+q-n}}{O_r \cdots O_0 O_q} \cdot \text{vol}_q(S).$$

Proof. Using (5.3) and the previous proposition,

$$\begin{aligned} \int_{\mathcal{L}_r^\lambda} \text{vol}_{r+q-n}(L_r^\lambda \cap S^q) dL_r^\lambda &= \int_{\mathcal{L}_{r+1}} \int_{\mathcal{L}_{[r+1]r}^\lambda} \text{vol}_{r+q-n}(L_r^\lambda \cap S^q) dL_{[r+1]r}^\lambda dL_{r+1} = \\ &= \frac{O_{r+1}O_{r+q-n}}{O_{r+1+q-n}} \int_{\mathcal{L}_{r+1}} \text{vol}_{r+1+q-n}(S \cap L_{r+1}) dL_{r+1}. \end{aligned}$$

The formula for the integral of the intersection volumes with geodesic planes (2.8) gives

$$\int_{\mathcal{L}_{r+1}} \text{vol}_{r+1+q-n}(S \cap L_{r+1}) dL_{r+1} = \frac{O_n \cdots O_{n-r-1} O_{r+1+q-n}}{O_{r+1} \cdots O_1 O_0 O_q} \text{vol}_q(S)$$

□

Note that for $\lambda = 0$, these formulas coincide with (2.8) up to a factor O_{n-r-1} . This agrees with the fact that, also for $\lambda = 0$, the space \mathcal{L}_r^λ is a fiber bundle of base \mathcal{L}_r and fiber S^{n-r-1} . Indeed, for every geodesic r -plane L_r consider the tube at distance $\epsilon = \text{arctanh} \lambda$. We get a ‘revolution’ hypersurface made of λ -geodesic r -planes. Now the unit normal vectors of L_r at a fixed point are in correspondence to the λ -geodesic r -planes of the tube.

For $r + q = n$, we have the following Cauchy-Crofton formula

$$\int_{\mathcal{L}_r^\lambda} \#(L_r^\lambda \cap S^q) dL_r^\lambda = \frac{O_n \cdots O_{n-r+1} O_{n-r-1}}{O_r \cdots O_1} \cdot \text{vol}_q(S)$$

In particular, the integral of the number of intersection points of a λ -hyperplane with a curve is $4/(O_{n-1} \cdots O_2)$ times its length. When $\lambda = 1$, this coincides with a result by Santaló for the cases $n = 2, 3$ and by Gallego, Martínez Naveira and the author for general n (cf.[San67, San68, GNS]).

5.4 Mean curvature integrals of intersections with λ -geodesic planes

Our aim is now to generalize proposition 2.2.4 replacing geodesic planes by λ -geodesic planes. Indeed, given a hypersurface $S \subset \mathbb{H}^n$, the intersection $S \cap L_r^\lambda$ is, for almost every L_r^λ , a hypersurface of L_r^λ . It has sense to consider the mean curvature integral $M_i(S \cap L_r^\lambda)$ of this hypersurface. Next we compute the integral of these value when L_r^λ moves over all the positions meeting S .

Let $L = L_{n-1}^\lambda$ be a λ -hyperplane meeting S . If $T_p S$ and $T_p L_{n-1}^\lambda$ are transverse in $p \in L_{n-1}^\lambda$, then $C = L \cap S$ is, at least locally, a codimension 2 submanifold. The second fundamental forms of these submanifolds are bilinear symmetric forms given by

$$\begin{aligned} h_L : (T_x L) \times (T_x L) &\longrightarrow (T_x L)^\perp & \nabla_X Y &= \nabla_X^L Y + h_L(X, Y) \\ h_S : (T_x S) \times (T_x S) &\longrightarrow (T_x S)^\perp & \nabla_X Y &= \nabla_X^S Y + h_S(X, Y) \\ h_C : (T_x C) \times (T_x C) &\longrightarrow (T_x C)^\perp & \nabla_X Y &= \nabla_X^C Y + h_C(X, Y). \end{aligned}$$

where ∇^M denotes the connection on the submanifold M . One can also consider the second fundamental form h_C^L (or h_C^S) of C as a submanifold of L (or of S). Clearly,

$$h_C(X, Y) = h_C^L(X, Y) + h_L(X, Y) = h_C^S(X, Y) + h_S(X, Y) \quad (5.6)$$

Let us orient S and L_{n-1}^λ respectively by the unit normals N_S and N_L . For $X, Y \in T_x C$ one has

$$h_S(X, Y) = \mathbb{I}_S(X, Y) \cdot N_S \quad h_L(X, Y) = \mathbb{I}_L(X, Y) \cdot N_L$$

where \mathbb{I}_S and \mathbb{I}_L are bilinear forms of $T_x S$ and $T_x L$, respectively, with real values. On the other hand, for some bilinear form \mathbb{I}_C^L of $T_x C$ with real values

$$h_C^L(X, Y) = \mathbb{I}_C^L(X, Y) N_C$$

where we have taken $N_C \in T_x L$ normal to C , unitary and such that $\langle N_C, N_S \rangle > 0$. The following proposition is a generalization of Meusnier's theorem.

Proposition 5.4.1. *With the above notation*

$$\mathbb{I}_S = \cos \theta \mathbb{I}_L + \sin \theta \mathbb{I}_C^L$$

where θ is the angle between N_L and N_S .

Proof. Using (5.6),

$$\mathbb{I}_S(X, Y) = \langle h_S(X, Y), N_S \rangle = \langle h_C(X, Y), N_S \rangle = \mathbb{I}_C^L(X, Y) \langle N_C, N_S \rangle + \mathbb{I}_L(X, Y) \langle N_L, N_S \rangle$$

□

Since $L = L_{n-1}^\lambda$ is totally umbilical with normal curvature λ , clearly $\mathbb{I}_L = \lambda Id$ and we can express \mathbb{I}_C^L in terms of the restriction of \mathbb{I}_S to $T_x C$

$$\mathbb{I}_C^L = \frac{\mathbb{I}_S}{\sin \theta} - \frac{\lambda Id}{\tan \theta}. \quad (5.7)$$

To avoid confusions we take the following notation. Given a real-valued bilinear symmetric form μ of rank r , denote

$$\sigma_j(\mu) = \frac{f_j(k_{i_1} \dots k_{i_j})}{\binom{r}{j}}$$

where $k_1 \dots k_r$ are the eigenvalues of μ and f_j is the j -th elementary symmetric polynomial.

Recall that

$$\det(\mu + tId) = \sum_{j=0}^r f_j(k_1, \dots, k_r) t^{r-j}.$$

With these notation, the j -th mean curvature $\sigma_j^S(x)$ of the hypersurface S in a point is $\sigma_j(\mathbb{I}_S)$.

Proposition 5.4.2. *The mean curvatures $\sigma_k(\mathbb{I}_C^L)$ of C as a hypersurface of L are given by*

$$\sigma_k(\mathbb{I}_C^L) = \sum_{l=0}^k \frac{\binom{n-l-2}{n-k-2} \binom{n-2}{l}}{\binom{n-2}{k}} (-1)^{k-l} \frac{\cos^{k-l} \theta}{\sin^k \theta} \lambda^{k-l} \sigma_l(\mathbb{I}_P^S)$$

where \mathbb{I}_P^S is the restriction of \mathbb{I}_S to $P = T_x C$.

Proof.

$$\mathbb{I}_C^L + tId = \frac{\mathbb{I}_P^S}{\sin \theta} + (t - \frac{\lambda}{\tan \theta})Id = \frac{1}{\sin \theta} (\mathbb{I}_P^S + (t \sin \theta - \lambda \cos \theta)Id)$$

Taking determinants

$$\begin{aligned} \sum_{j=0}^{n-2} \binom{n-2}{j} \sigma_{n-j-2}(\mathbb{I}_C^L) t^j &= \det(\mathbb{I}_C + tId) = \frac{1}{\sin^{n-2} \theta} \det(\mathbb{I}_P^S + (t \sin \theta - \lambda \cos \theta)Id) = \\ &= \frac{1}{\sin^{n-2} \theta} \sum_{i=0}^{n-2} \binom{n-2}{i} \sigma_{n-i-2}(\mathbb{I}_P^S) (t \sin \theta - \lambda \cos \theta)^i = \\ &= \frac{1}{\sin^{n-2} \theta} \sum_{i=0}^{n-2} \binom{n-2}{i} \sigma_{n-i-2}(\mathbb{I}_P^S) \sum_{j=0}^i \binom{i}{j} (-1)^{i-j} \lambda^{i-j} \cos^{i-j} \theta \sin^j \theta t^j = \\ &= \sum_{j=0}^{n-2} \frac{1}{\sin^{n-j-2} \theta} \left(\sum_{i=j}^{n-2} \binom{i}{j} \binom{n-2}{i} (-1)^{i-j} \lambda^{i-j} \cos^{i-j} \theta \sigma_{n-i-2}(\mathbb{I}_P^S) \right) t^j \end{aligned}$$

□

The following lemma is a generalization of (1.2.1).

Lemma 5.4.3. *Let S be a hypersurface of some n -dimensional Riemann manifold and let \mathbb{I} be the second fundamental form of S at a point x . For every i -dimensional linear subspace P of $T_x S$, denote by $\mathbb{I}|_P$ the restriction of \mathbb{I} to P . Then, for $j \leq i < n-1$*

$$\sigma_j(\mathbb{I}) = \frac{1}{\text{vol}(G(i, n-1))} \int_{G(i, T_x S)} \sigma_j(\mathbb{I}|_P) dP.$$

Clearly $\sigma_j(\mathbb{I}|_P)$ is a generalization of the notion of normal curvature. Besides, if another hypersurface L meets S orthogonally in x in such a way that $T_x L \cap T_x S = P$, by the proposition 5.4.1, $\mathbb{I}|_P$ is the second fundamental form of $S \cap L$ at x as a hypersurface of R . Thus, $\sigma_r(\mathbb{I}|_P)$ is the r -th mean curvature of $S \cap L$.

Proof. The case $j = i$ is the known proposition (1.2.1). For $j < i$ we can reduce to the previous case as follows

$$\begin{aligned}
 \int_{G(i, T_x S)} \sigma_j(\mathbb{I}|_P) dP &= \int_{G(i, T_x S)} \left(\text{vol}(G(j, i))^{-1} \int_{G(j, P)} \sigma_j(\mathbb{I}|_l) dl \right) dP = \\
 &= \text{vol}(G(j, i))^{-1} \int_{G(j, T_x S)} \int_{G(i-j, l^\perp)} \sigma_j(\mathbb{I}|_l) dP dl = \\
 &= \text{vol}(G(j, i))^{-1} \text{vol}(G(i-j, n-j-1)) \int_{G(j, T_x S)} \sigma_j(\mathbb{I}|_l) dl = \\
 &= \text{vol}(G(j, i))^{-1} \text{vol}(G(i-j, n-j-1)) \text{vol}(G(j, n-1)) \sigma_j(\mathbb{I})
 \end{aligned}$$

□

Given a hypersurface $S \subset \mathbb{H}^n$, for almost every λ -hyperplane L_{n-1}^λ , the intersection $L_{n-1}^\lambda \cap S$ is a smooth hypersurface of L_{n-1}^λ . In such cases, one can consider $M_i(L_{n-1}^\lambda \cap S)$, the mean curvature integrals of $L_{n-1}^\lambda \cap S$ as a hypersurface of L_{n-1}^λ .

Proposition 5.4.4. *If S is a hypersurface of \mathbb{H}^n then the integral over all the λ -geodesic hyperplanes of $M_i(L_{n-1}^\lambda \cap S)$ is a polynomial in λ^2 whose coefficients are multiples of the mean curvature integrals $M_j(S)$. To be precise,*

$$\int_{\mathcal{L}_{n-1}^\lambda} M_j(L_{n-1}^\lambda \cap S) dL_{n-1}^\lambda = \sum_{l=0}^{[j/2]} c_{l,j}^n \lambda^{2l} M_{j-2l}(S).$$

where

$$c_{l,j}^n = \frac{\binom{n-j+2l-2}{n-j-2} \binom{n-2}{j-2l} O_{n-2} O_{n-j+2l} O_0}{\binom{n-2}{j} O_{n-j-1} O_{2l}}.$$

For $\lambda = 0$ we recover the formula (2.2.4) but again with an extra factor O_{n-r-1} .

Proof. Denote $C = L_{n-1}^\lambda \cap S$. Using the expression (5.5)

$$\int_{\mathcal{L}_{n-1}^\lambda} \int_C \sigma_j^C dx dL_{n-1}^\lambda = \int_S \int_{\mathbb{S}^{n-1}} \sin \theta \sigma_j^C du dx.$$

By the proposition 5.4.2, if \mathbb{I}_P^S is the restriction of \mathbb{I}_S to $P = T_x C$, then

$$\begin{aligned}
 &\binom{n-2}{j} \int_{\mathbb{S}^{n-1}} \sin \theta \sigma_j^C du = \\
 &= \int_{\mathbb{S}^{n-1}} \frac{\sin \theta}{\sin^j \theta} \sum_{i=0}^j \binom{n-i-2}{n-j-2} \binom{n-2}{i} (-1)^{j-i} \cos^{j-i} \theta \lambda^{j-i} \sigma_i(\mathbb{I}_P^S) du
 \end{aligned}$$

which, taking polar coordinates in \mathbb{S}^{n-1} , is equal to

$$\begin{aligned} &= \sum_{i=0}^j \binom{n-i-2}{n-j-2} \binom{n-2}{i} (-1)^{j-i} \int_{\mathbb{S}^{n-2}} \int_0^\pi \frac{1}{\sin^{j-1} \theta} \cos^{j-i} \theta \lambda^{j-i} \sigma_i(\mathbb{I}_P^S) \sin^{n-2} \theta d\theta dP = \\ &= \sum_{i=0}^j \binom{n-i-2}{n-j-2} \binom{n-2}{i} (-1)^{j-i} \lambda^{j-i} \int_0^\pi \sin^{n-j-1} \theta \cos^{j-i} \theta d\theta \int_{\mathbb{S}^{n-2}} \sigma_i(\mathbb{I}_P^S) dP. \end{aligned}$$

Using lemma 5.4.3 we get the desired formula. The constants are easily computed. \square

Corollary 5.4.5. For $j \leq r-1$

$$\int_{\mathcal{L}_r^\lambda} M_j(L_r^\lambda \cap S) dL_r^\lambda = \sum_{l=0}^{\lfloor j/2 \rfloor} c_{l,j,r}^n \lambda^{2l} M_{j-2l}(S)$$

where

$$c_{l,j,r}^n = \frac{\binom{r-j+2l-1}{r-j-1} \binom{r-1}{j-2l} O_{n-2} \dots O_{n-r-1} O_{n-j+2l}}{\binom{r-1}{j} O_{r-2} \dots O_1 O_{r-j} O_{2l}}.$$

Remark. For $j=0$ we recover the case $q=n-1$ of the proposition 5.3.2.

Proof. The expression (5.3) for dL_r^λ gives

$$\int_{\mathcal{L}_r^\lambda} M_j(L_r^\lambda \cap S) dL_r^\lambda = \int_{\mathcal{L}_{r+1}} \int_{\mathcal{L}_{[r+1]r}^\lambda} M_j(L_r^\lambda \cap S) dL_{[r+1]r}^\lambda dL_{r+1}$$

which, by the last proposition, is equal to

$$\int_{\mathcal{L}_{r+1}} \left(\sum_{l=0}^{\lfloor j/2 \rfloor} c_{l,j}^{r+1} \lambda^{2l} M_{j-2l}(S \cap L_{r+1}) \right) dL_{r+1}.$$

Finally, the reproductibility formula for the mean curvature integrals through intersections with geodesic planes of proposition (2.2.4) gives

$$\sum_{l=0}^{\lfloor j/2 \rfloor} c_{l,j}^{r+1} \lambda^{2l} \int_{\mathcal{L}_{r+1}} M_{j-2l}(S \cap L_{r+1}) dL_{r+1} = \sum_{l=0}^{\lfloor j/2 \rfloor} c_{l,j}^{r+1} \lambda^{2l} \frac{O_{n-2} \dots O_{n-r-1} O_{n-j+2l}}{O_{r-1} \dots O_0 O_{r-j+2l+1}} M_{j-2l}(S).$$

\square

These formulas do not look very simple nor pretty. However, it is interesting to note that all the coefficients are positive. This means that when all the mean curvature integrals of S are positive, for instance if S bounds a convex body, then all the integrals considered are positive. This was not clear *a priori* since, for instance, the intersection of a λ -geodesic hyperplane L_{n-1}^λ with a convex set can be non-convex inside $L_{n-1}^\lambda \equiv \mathbb{H}^{n-1}$.

5.5 Measure of λ -geodesic planes meeting a λ -convex domain.

Next we generalize the formulas (2.10) and (2.11) by replacing geodesic planes by λ -geodesic planes. That is, we will express the integral of the Euler characteristic of the intersection of λ -geodesic planes with a domain of \mathbb{H}^n in terms of the mean curvature integrals of its boundary and in terms of its volume.

Theorem 5.5.1. *Let $Q \subset \mathbb{H}^n$ be a compact domain with smooth boundary. For even r*

$$\int_{\mathcal{L}_r^\lambda} \chi(Q \cap L_r^\lambda) dL_r^\lambda = (\lambda^2 - 1)^{r/2} \frac{O_{n-1} \cdots O_{n-r-1}}{O_r \cdots O_1} \cdot V(Q) + \sum_{j=1}^{r/2} \left(\sum_{i=j}^{r/2} \binom{r-1}{2i-1} \frac{2}{O_{2i-1} O_{r-2i}} c_{i-j, 2i-1, r}^n (\lambda^2 - 1)^{\frac{r-2i}{2}} \lambda^{2i-2j} \right) M_{2j-1}(\partial Q),$$

and for odd r

$$\int_{\mathcal{L}_r^\lambda} \chi(Q \cap L_r^\lambda) dL_r^\lambda = \sum_{j=0}^{(r-1)/2} \left(\sum_{i=j}^{(r-1)/2} \binom{r-1}{2i} \frac{2}{O_{2i} O_{r-2i-1}} c_{i-j, 2i, r}^n (\lambda^2 - 1)^{\frac{r-2i-1}{2}} \lambda^{2i-2j} \right) M_{2j}(\partial Q).$$

Proof. We know that each L_r^λ is a simply connected manifold of constant sectional curvature $\lambda^2 - 1$. Now, for L_r^λ meeting Q , the Gauss-Bonnet theorem in spaces of constant curvature $\lambda^2 - 1$ states that, for even r ,

$$\frac{O_r}{2} \chi(Q \cap L_r^\lambda) = (\lambda^2 - 1)^{r/2} V(Q \cap L_r^\lambda) + \sum_{i=1}^{r/2} \binom{r-1}{2i-1} \frac{O_r}{O_{2i-1} O_{r-2i}} (\lambda^2 - 1)^{(r-2i)/2} M_{2i-1}(\partial Q \cap L_r^\lambda);$$

and for odd r ,

$$\frac{O_r}{2} \chi(Q \cap L_r^\lambda) = \sum_{i=0}^{(r-1)/2} \binom{r-1}{2i} \frac{O_r}{O_{2i} O_{r-2i-1}} (\lambda^2 - 1)^{(r-2i-1)/2} M_{2i}(\partial Q \cap L_r^\lambda).$$

Integrating with respect to L_r^λ , in the even case

$$\frac{O_r}{2} \int_{\mathcal{L}_r^\lambda} \chi(Q \cap L_r^\lambda) dL_r^\lambda = (\lambda^2 - 1)^{r/2} \int_{\mathcal{L}_r^\lambda} V(Q \cap L_r^\lambda) dL_r^\lambda + \sum_{i=1}^{r/2} \binom{r-1}{2i-1} \frac{O_r}{O_{2i-1} O_{r-2i}} (\lambda^2 - 1)^{(r-2i)/2} \int_{\mathcal{L}_r^\lambda} M_{2i-1}(\partial Q \cap L_r^\lambda) dL_r^\lambda$$

and by corollary 5.4.5 and the proposition 5.3.2,

$$\begin{aligned} \frac{O_r}{2} \int_{\mathcal{L}_r^\lambda} \chi(Q \cap L_r^\lambda) dL_r^\lambda &= (\lambda^2 - 1)^{r/2} \frac{O_{n-1} \cdots O_{n-r-1}}{O_{r-1} \cdots O_0} \cdot V(Q) + \\ &+ \sum_{i=1}^{r/2} \binom{r-1}{2i-1} \frac{O_r}{O_{2i-1} O_{r-2i}} (\lambda^2 - 1)^{(r-2i)/2} \left(\sum_{l=0}^{i-1} c_{l,2i-1,r}^n \lambda^{2l} M_{2i-2l-1}(\partial Q) \right) \end{aligned}$$

and reordering the sums we get the desired formula. In the odd case one proceeds analogously. \square

For $\lambda = 1$ and $r = n - 1$ we get the integral of the Euler characteristic of intersections with horospheres (as in [San67],[San68] and [GNS]).

Remark. These results are specially interesting in the case of λ -convex domains (cf. definition 1.1.2). It is easy to see that when Q is a λ -convex domain, then $L_r^\lambda \cap Q$ is contractible for every L_r^λ . Thus, the previous formulas give the measure of λ -geodesic r -planes meeting Q . For instance, the measure of λ -geodesic planes in \mathbb{H}^3 meeting a λ -convex domain is

$$\int_{L_2^\lambda \cap Q \neq \emptyset} dL_2^\lambda = 2M_1(\partial Q) - (1 - \lambda^2)V(Q).$$

To simplify we can state the following corollary.

Corollary 5.5.2. *The measure of the set of λ -geodesic r -planes meeting a λ -convex domain $Q \subset \mathbb{H}^n$ is a linear combination of the mean curvature integrals of ∂Q and, when r is odd, the volume of Q .*

5.6 h -convex domains

For short let us denote by \mathcal{H} the space of horospheres which was denoted so far by \mathcal{L}_{n-1}^1 . Besides we will call *horoballs* to the convex regions bounded by horospheres. In general we will denote by H the horoball in such a way that the horospheres will be denoted by ∂H . In this section we shall measure the set of horoballs containing an h -convex domain. This will lead to some interesting inequalities for this kind of domains.

Start noting that from (5.4) one deduces that the total measure of d 'horoballs containing a point p is finite. Indeed, this measure is

$$\int_{\mathbb{S}^{n-1}} \int_0^\infty e^{-\rho} d\rho du = O_{n-1}$$

Our aim is to find the measure of horoballs containing an h -convex domain Q . Note that this is the difference of the measure of the horoballs meeting Q and the measure of horospheres meeting Q .

Recall the fundamental kinematic formula (2.2.6) in \mathbb{H}^n which, given two domains Q_0 and Q_1 , states for even n

$$\begin{aligned} \int_G \chi(Q_0 \cap gQ_1) dK = & -2(-1)^{n/2} \frac{O_{n-1} \cdots O_1}{O_n} V(Q_0)V(Q_1) + \\ & + O_{n-1} \cdots O_1 (V(Q_1)\chi(Q_0) + V(Q_0)\chi(Q_1)) + \\ & + O_{n-2} \cdots O_1 \frac{1}{n} \sum_{h=0}^{n-2} \binom{n}{h+1} M_h(\partial Q_0) M_{n-2-h}(\partial Q_1) + \\ & + O_{n-2} \cdots O_1 \sum_{i=0}^{n/2-2} (-1)^{(n/2-i-1)} \binom{n-1}{2i+1} \frac{n-2i-2}{O_{n-2i-3}} \frac{2}{O_{n-2i-2}} \\ & \cdot \left[\sum_{h=n-2i-2}^{n-2} \frac{\binom{2i+1}{n-h-1} O_{2n-h-2i-2}}{(h+1)O_{n-h}} \frac{O_h}{O_{2i+h-n+2}} M_{n-2-h}(\partial Q_0) M_{h+2i+2-n}(\partial Q_1) \right]. \end{aligned}$$

and for odd n

$$\begin{aligned} \int_G \chi(Q_0 \cap gQ_1) dK = & O_{n-1} \cdots O_1 (V(Q_1)\chi(Q_0) + V(Q_0)\chi(Q_1)) + \\ & + O_{n-2} \cdots O_1 \frac{1}{n} \sum_{h=0}^{n-2} \binom{n}{h+1} M_h(\partial Q_0) M_{n-2-h}(\partial Q_1) + \\ & + O_{n-2} \cdots O_1 \sum_{i=0}^{(n-3)/2} (-1)^{(n-2i-1)/2} \binom{n-1}{2i} \frac{n-2i-1}{O_{n-2i-1}} \frac{2}{O_{n-2i-2}} \\ & \cdot \left[\sum_{h=n-2i-1}^{n-2} \frac{\binom{2i}{n-h-1} O_{2n-h-2i-1}}{(h+1)O_{n-h}} \frac{O_h}{O_{2i+h-n+1}} M_{n-2-h}(\partial Q_0) M_{h+2i+1-n}(\partial Q_1) \right]. \end{aligned}$$

In the same way as in [GNS], take Q_1 to be a radius R sphere and normalize with $dS_r = dK/(O_{n-2} \cdots O_0 \text{vol}(S_r))$. This way $dS_r = dL_{n-1}^\lambda$ where $\lambda = \coth r$. It is clear that $\lim_r dS_r = dH$. Thus, the integral of $\chi(Q_0 \cap H)$ over all the horoballs H meeting Q_0 is obtained by dividing the previous expressions by $(O_{n-2} \cdots O_0) \text{vol}(S_r)$ and making

r go to infinity. Bearing in mind that $\lim_r M_i(S_r)/\text{vol}(S_r) = 1$ we get, for even n

$$\begin{aligned} \int_{\mathcal{H}} \chi(Q_0 \cap H) dH &= -2(-1)^{n/2} \frac{O_{n-1}}{(n-1)O_n} V(Q_0) + O_{n-1} \left(\frac{1}{n-1} \chi(Q_0) \right) + \\ &+ \frac{1}{n} \sum_{h=0}^{n-2} \binom{n}{h+1} M_h(\partial Q_0) + \sum_{i=0}^{n/2-2} (-1)^{(n/2-i-1)} \binom{n-1}{2i+1} \frac{n-2i-2}{O_{n-2i-3}} \frac{2}{O_{n-2i-2}} \\ &\cdot \left[\sum_{h=n-2i-2}^{n-2} \frac{\binom{2i+1}{n-h-1} O_{2n-h-2i-2}}{(h+1)O_{n-h}} \frac{O_h}{O_{2i+h-n+2}} M_{n-2-h}(\partial Q_0) \right], \end{aligned}$$

and for odd n

$$\begin{aligned} \int_{\mathcal{H}} \chi(Q_0 \cap H) dH &= O_{n-1} \left(\frac{1}{n-1} \chi(Q_0) \right) + \\ &+ \frac{1}{n} \sum_{h=0}^{n-2} \binom{n}{h+1} M_h(\partial Q_0) + \sum_{i=0}^{(n-3)/2} (-1)^{(n-2i-1)/2} \binom{n-1}{2i} \frac{n-2i-1}{O_{n-2i-1}} \frac{2}{O_{n-2i-2}} \\ &\cdot \left[\sum_{h=n-2i-1}^{n-2} \frac{\binom{2i}{n-h-1} O_{2n-h-2i-1}}{(h+1)O_{n-h}} \frac{O_h}{O_{2i+h-n+1}} M_{n-2-h}(\partial Q_0) \right]. \end{aligned}$$

On the other hand, the integral of the Euler characteristic of the intersection of Q_0 with the horospheres ∂H is

$$\int_{\mathcal{H}} \chi(Q_0 \cap \partial H) dH = 2 \sum_{h=0}^{[(n-2)/2]} \binom{n-2}{2h} \frac{1}{2h+1} M_{n-2h-2}(\partial Q_0).$$

Assuming Q_0 to be h -convex, all the intersections are contractible and the Euler characteristics are 1 (or 0). Thus, subtracting we get the measure of horoballs containing Q_0 . Since the formulas are very complicated, we give the results in dimensions $n = 2, 3, 4, 5$ and 6.

$$m = F - L + 2\pi \quad n = 2$$

$$m = M_0 - M_1 + 2\pi \quad n = 3$$

$$m = -\frac{1}{3}M_0 + \frac{3}{2}M_1 - M_2 - \frac{1}{2}V + \frac{2}{3}\pi^2 \quad n = 4$$

$$m = -M_1 + 2M_2 - M_3 + \frac{2}{3}\pi^2 \quad n = 5$$

$$m = -\frac{1}{5}M_0 + \frac{5}{8}M_1 - 2M_2 + \frac{5}{2}M_3 - M_4 + \frac{1}{5}\pi^3 + \frac{3}{8}V \quad n = 6$$

All these values m are positive assuming h -convexity. This estimation is *sharp*: for a sequence of balls filling a horoball they go to 0. In fact, it is clear that for any sequence

of h -convex sets with diameter going to infinity these measures m must go to 0. An important fact is that m is decreasing in the space of h -convex domains (with respect to inclusion). Thus, the value of m is always below its constant term. A stronger consequence is that if B_R is a ball containing Q and B_r is another one contained in Q , then

$$m(B_R) \leq m(Q) \leq m(B_r).$$

The cases $n = 2$ and 3 are really interesting

$$0 \leq L - F \leq 2\pi \quad 0 \leq M_1 - M_0 \leq 2\pi.$$

It was seen in [BM99] for any sequence of h -convex domains expanding over \mathbb{H}^n , that the quotients M_i/M_0 tend to 1. In fact, the same is true in manifolds of negative bounded curvature (cf. [BM02]). In \mathbb{H}^2 and \mathbb{H}^3 we have just seen something stronger. For a sequence (Q_r) of h -convex domains expanding to fill \mathbb{H}^2

$$M_1(\partial Q) - M_0(\partial Q_r) = F(Q_r) + 2\pi - L(\partial Q_r) = m(Q_r) \leq m(B_r) \longrightarrow 0 \quad r \rightarrow \infty$$

where B_r is the biggest disk contained in Q_r . Which is stronger than $M_1/M_0 \rightarrow 1$. In \mathbb{H}^3 ,

$$M_0(\partial Q_r) - M_1(\partial Q_r) + 2\pi = m(Q_r) \leq m(B_r) \longrightarrow 0 \quad r \rightarrow \infty$$

where B_r is the biggest ball contained in Q_r . Again this implies $M_1/M_0 \rightarrow 1$.

Remark. It is a remarkable fact that, for h -convex domains in \mathbb{H}^2 , $L - F$ is increasing. We wonder if it is true in general that $M_0 - (n - 1)V$ is increasing in the space of h -convex domains of \mathbb{H}^n .

5.7 Expected slice with λ -geodesic planes

Here we prove analogous results to those of section 4.3. That is, we give upper bounds for the expected volume of the intersection of a λ -convex domain with a random λ -hyperplane.

Given a λ -convex domain $Q \subset \mathbb{H}^n$. Consider the random variable consisting to throw randomly a λ -hyperplane L_{n-1}^λ meeting Q and to measure the volume of the intersection. By propositions 5.3.1 and 5.5.1 this expectation is

$$E[\text{vol}(Q \cap L_{n-1}^\lambda)] = \frac{\int_{\mathcal{L}_{n-1}^\lambda} \text{vol}(Q \cap L_{n-1}^\lambda) dL_{n-1}^\lambda}{\int_{\mathcal{L}_{n-1}^\lambda} \chi(Q \cap L_{n-1}^\lambda) dL_{n-1}^\lambda} = \frac{O_{n-1}V(Q)}{\sum_i c_i M_i(\partial Q) + cV}$$

where the denominator of the last term is one of the expressions of proposition 5.5.1. As in the geodesic case, no matter how big the domain is, the expectation is below some bound.

Proposition 5.7.1. *Let $Q \subset B(R) \subset \mathbb{H}^n$ be a domain contained in a radius R ball. The expected the volume of the intersection of Q with a random λ -hyperplane is bounded by*

$$E[\text{vol}(Q \cap L_{n-1}^\lambda)] \leq E[\text{vol}(B(R) \cap L_{n-1}^\lambda)] < \frac{O_{n-1}}{(1 + \lambda)^{n-1} + (1 - \lambda)^{n-1}}$$

Proof. We can assume Q to be λ -convex by taking its λ -convex hull, the smallest λ -convex domain containing it. Take an origin O interior to Q . For every unit vector u in $T_O\mathbb{H}^n$ take the geodesic $\gamma(\rho) = \exp_O(\rho u)$ and assign to ρ the λ -hyperplane L_{n-1}^λ orthogonal to γ in $\gamma(\rho)$ and with the convexity by the side of $-\gamma'(\rho)$. By the expression (5.4) of the measure of λ -hyperplanes we have

$$\begin{aligned} \int_{\mathcal{L}_{n-1}^\lambda} \chi(Q \cap L_{n-1}^\lambda) dL_{n-1}^\lambda &= \int_{\mathbb{S}^{n-1}} \int_{h_1(u)}^{h_2(u)} (\cosh \rho - \lambda \sinh \rho)^{n-1} d\rho du \geq \\ &\geq \int_{\mathbb{S}^{n-1}} \int_{l_1(u)}^{l_2(u)} (\cosh \rho - \lambda \sinh \rho)^{n-1} d\rho du \end{aligned}$$

where $[h_1(u), h_2(u)]$ is the interval of values ρ of corresponding to λ -hyperplanes meeting Q , and $[l_1(u), l_2(u)] = \gamma^{-1}(Q \cap \gamma)$ is the interval of parameters where γ is interior to Q . Since $l_1(-u) = -l_2(u)$ the last integral is

$$\int_{\mathbb{S}^{n-1}} \int_0^{l_2(u)} (\cosh \rho - \lambda \sinh \rho)^{n-1} + (\cosh \rho + \lambda \sinh \rho)^{n-1} d\rho du.$$

On the other hand, the volume of Q expressed in polar coordinates is

$$V(Q) = \int_{\mathbb{S}^{n-1}} \int_0^{l_2(u)} \sinh^{n-1} \rho d\rho du.$$

Now, studying the function

$$f(R) = E[\text{vol}(B(R) \cap L_{n-1}^\lambda)] = \frac{O_{n-1} \int_0^R \sinh^{n-1} \rho d\rho}{\int_0^R (\cosh \rho - \lambda \sinh \rho)^{n-1} + (\cosh \rho + \lambda \sinh \rho)^{n-1} d\rho}$$

one can see that it is increasing and bounded by $O_{n-1}((1+\lambda)^{n-1} + (1-\lambda)^{n-1})^{-1}$. Thus, since $l_2(u) \leq R$ for every u ,

$$\begin{aligned} \frac{V(Q)}{E[L_r^\lambda \cap Q]} &= \int_{\mathcal{L}_{n-1}^\lambda} \chi(Q \cap L_{n-1}^\lambda) dL_{n-1}^\lambda \geq \\ &\geq O_{n-1} \int_{\mathbb{S}^{n-1}} \int_0^{l_2(u)} (\cosh \rho - \lambda \sinh \rho)^{n-1} + (\cosh \rho + \lambda \sinh \rho)^{n-1} d\rho du = \\ &= \int_{\mathbb{S}^{n-1}} \frac{1}{f(l_2(u))} \int_0^{l_2(u)} \sinh^{n-1} \rho d\rho du \geq \int_{\mathbb{S}^{n-1}} \frac{1}{f(R)} \int_0^{l_2(u)} \sinh^{n-1} \rho d\rho du = \\ &= \frac{V(B(R))}{E[L_r^\lambda \cap B(R)]}. \end{aligned}$$

□

Bibliography

- [BGR01] A. A. Borisenko, E. Gallego, and A. Reventós. Relation between area and volume for λ -convex sets in Hadamard manifolds. *Differential Geom. Appl.*, 14(3):267–280, 2001.
- [BK97] P. Breuer and W. Kühnel. The tightness of tubes. *Forum Math.*, 9(6):707–720, 1997.
- [BM99] A. A. Borisenko and V. Miquel. Total curvatures of convex hypersurfaces in hyperbolic space. *Illinois J. Math.*, 43(1):61–78, 1999.
- [BM02] A. A. Borisenko and V. Miquel. Comparison theorems on convex hypersurfaces in Hadamard manifolds. *Ann. Global Anal. Geom.*, 21(2):191–202, 2002.
- [BV97] A. A. Borisenko and D. I. Vlasenko. Convex surfaces in Lobachevskii space. *Mat. Fiz. Anal. Geom.*, 4(3):278–285, 1997.
- [Car51] E. Cartan. *Leçons sur la géométrie des espaces de Riemann*. Gauthier-Villars, Paris, 1951. 2d ed.
- [Che44] S-S. Chern. A simple intrinsic proof of the Gauss-Bonnet formula for closed Riemannian manifolds. *Ann. of Math. (2)*, 45:747–752, 1944.
- [Che45] S-S. Chern. On the curvatura integra in a Riemannian manifold. *Ann. of Math. (2)*, 46:674–684, 1945.
- [CL57] S-S Chern and R.K. Lashof. On the total curvature of immersed manifolds. *Amer. J. Math.*, 79:306–318, 1957.
- [CR79] T.E. Cecil and P.J. Ryan. Tight and taut immersions into hyperbolic space. *J. London Math. Soc. (2)*, 19(3):561–572, 1979.
- [dC92] M. P. do Carmo. *Riemannian geometry*. Mathematics: Theory & Applications. Birkhäuser Boston Inc., Boston, MA, 1992. Translated from the second Portuguese edition by Francis Flaherty.
- [Fed69] H. Federer. *Geometric measure theory*. Die Grundlehren der mathematischen Wissenschaften, Band 153. Springer-Verlag New York Inc., New York, 1969.

Bibliography

- [GNS] E. Gallego, A. M. Naveira, and G. Solanes. Horospheres and convex bodies in n -dimensional hyperbolic space. *Geometria Dedicata*.
- [Got96] D.H. Gottlieb. All the way with Gauss-Bonnet and the sociology of mathematics. *Amer. Math. Monthly*, 103(6):457–469, 1996.
- [GR85] E. Gallego and A. Reventós. Asymptotic behavior of convex sets in the hyperbolic plane. *J. Differential Geom.*, 21(1):63–72, 1985.
- [GR99] E. Gallego and A. Reventós. Asymptotic behaviour of λ -convex sets in the hyperbolic plane. *Geom. Dedicata*, 76(3):275–289, 1999.
- [Gra90] A. Gray. *Tubes*. Addison-Wesley Publishing Company Advanced Book Program, Redwood City, CA, 1990.
- [GS01] E. Gallego and G. Solanes. Perimeter, diameter and area of convex sets in the hyperbolic plane. *J. London Math. Soc. (2)*, 64(1):161–178, 2001.
- [Had57] H. Hadwiger. *Vorlesungen über Inhalt, Oberfläche und Isoperimetrie*. Springer-Verlag, Berlin, 1957.
- [Hel01] S. Helgason. *Differential geometry, Lie groups, and symmetric spaces*, volume 34 of *Graduate Studies in Mathematics*. American Mathematical Society, Providence, RI, 2001. Corrected reprint of the 1978 original.
- [Hop25] H. Hopf. Über die curvatura integra geschlossener hyperflächen. *Math. Annalen*, 95:340–376, 1925.
- [Hop27] H. Hopf. Vektorfelder in n -dimensionalen mannigfaltigkeiten. *Math. Annalen*, 96:225–250, 1927.
- [KN96a] S. Kobayashi and K. Nomizu. *Foundations of differential geometry. Vol. I*. Wiley Classics Library. John Wiley & Sons Inc., New York, 1996. Reprint of the 1963 original, A Wiley-Interscience Publication.
- [KN96b] S. Kobayashi and K. Nomizu. *Foundations of differential geometry. Vol. II*. Wiley Classics Library. John Wiley & Sons Inc., New York, 1996. Reprint of the 1969 original, A Wiley-Interscience Publication.
- [Koh91] P. Kohlmann. Curvature measures and Steiner formulae in space forms. *Geom. Dedicata*, 40(2):191–211, 1991.
- [KP85] W. Kühnel and U. Pinkall. Tight smoothing of some polyhedral surfaces. In *Global differential geometry and global analysis 1984 (Berlin, 1984)*, volume 1156 of *Lecture Notes in Math.*, pages 227–239. Springer, Berlin, 1985.
- [Kui97] N.H. Kuiper. Geometry in curvature theory. In *Tight and taut submanifolds (Berkeley, CA, 1994)*, volume 32 of *Math. Sci. Res. Inst. Publ.*, pages 1–50. Cambridge Univ. Press, Cambridge, 1997.

-
- [Lan97] R. Langevin. *Introduction to integral geometry*. 21^o Colóquio Brasileiro de Matemática. [21st Brazilian Mathematics Colloquium]. Instituto de Matemática Pura e Aplicada (IMPA), Rio de Janeiro, 1997.
- [LS82] R. Langevin and T. Shifrin. Polar varieties and integral geometry. *Amer. J. Math.*, 104(3):553–605, 1982.
- [LS00] R. Langevin and G. Solanes. On bounds for total absolute curvature of surfaces in hyperbolic 3-space. *Prep.Lab.Top.Univ.Bourgogne*, (234), 2000.
- [Mil97] J.W. Milnor. *Topology from the differentiable viewpoint*. Princeton Landmarks in Mathematics. Princeton University Press, Princeton, NJ, 1997. Based on notes by David W. Weaver, Revised reprint of the 1965 original.
- [Mor29] M. Morse. Singular points of vector fields under general boundary conditions. *Amer. J. Math.*, 51:165–178, 1929.
- [O’N83] B. O’Neill. *Semi-Riemannian geometry*, volume 103 of *Pure and Applied Mathematics*. Academic Press Inc. [Harcourt Brace Jovanovich Publishers], New York, 1983. With applications to relativity.
- [Rat94] J. G. Ratcliffe. *Foundations of hyperbolic manifolds*, volume 149 of *Graduate Texts in Mathematics*. Springer-Verlag, New York, 1994.
- [San50] L. A. Santaló. On parallel hypersurfaces in the elliptic and hyperbolic n -dimensional space. *Proc. Amer. Math. Soc.*, 1:325–330, 1950.
- [San67] L. A. Santaló. Horocycles and convex sets in hyperbolic plane. *Arch. Math. (Basel)*, 18:529–533, 1967.
- [San68] L. A. Santaló. Horospheres and convex bodies in hyperbolic space. *Proc. Amer. Math. Soc.*, 19:390–395, 1968.
- [San70] L. A. Santaló. Probabilidades sobre cuerpos convexos y cilindros. *Rev. Unin Mat. Argentina*, 25:95–104, 1970.
- [San76] L. A. Santaló. *Integral geometry and geometric probability*. Addison-Wesley Publishing Co., Reading, Mass.-London-Amsterdam, 1976. With a foreword by Mark Kac, *Encyclopedia of Mathematics and its Applications*, Vol. 1.
- [San80] L. A. Santaló. Notes on the integral geometry in the hyperbolic plane. *Portugal. Math.*, 39(1-4):239–249 (1985), 1980. Special issue in honor of António Monteiro.
- [Spi79] M. Spivak. *A comprehensive introduction to differential geometry*. Vol. IV. Publish or Perish Inc., Wilmington, Del., second edition, 1979.
- [SY72] L. A. Santaló and I. Yañez. Averages for polygons formed by random lines in Euclidean and hyperbolic planes. *J. Appl. Probability*, 9:140–157, 1972.

- [Teu80] E. Teufel. Anwendungen der differentialtopologischen Berechnung der totalen Krümmung und totalen Absolutkrümmung in der sphärischen Differentialgeometrie. *Manuscripta Math.*, 32(3-4):239–262, 1980.
- [Teu86] E. Teufel. Integral geometry and projection formulas in spaces of constant curvature. *Abh. Math. Sem. Univ. Hamburg*, 56:221–232, 1986.
- [Teu88] E. Teufel. On the total absolute curvature of immersions into hyperbolic spaces. In *Topics in differential geometry, Vol. I, II (Debrecen, 1984)*, volume 46 of *Colloq. Math. Soc. János Bolyai*, pages 1201–1209. North-Holland, Amsterdam, 1988.
- [Teu82] E. Teufel. Differential topology and the computation of total absolute curvature. *Math. Ann.*, 258(4):471–480, 1981/82.
- [WS66] T. J. Willmore and B. A. Saleemi. The total absolute curvature of immersed manifolds. *J. London Math. Soc.*, 41:153–160, 1966.
- [Yau75] S. T. Yau. Isoperimetric constants and the first eigenvalue of a compact Riemannian manifold. *Ann. Sci. École Norm. Sup. (4)*, 8(4):487–507, 1975.